

| Code | Type | Drive Direction | Material | Surface Treatment |
|-------|-----------------|---------------------------|----------------|-------------------|
| EJW01 | Micrometer Head | Horizontal Surface Z-Axis | Aluminum Alloy | Black Anodize |

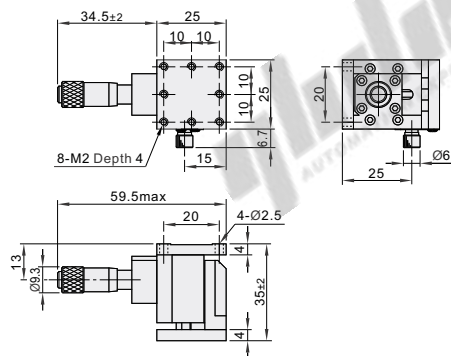

Self-made

No.: 25



No.: 40

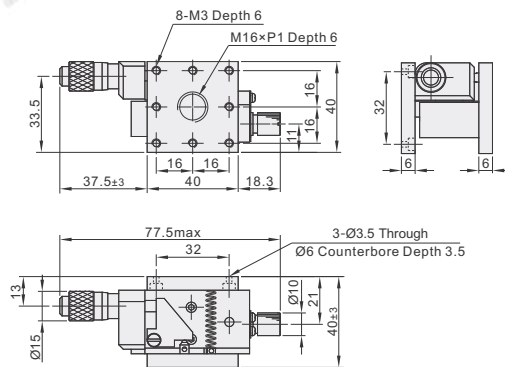

No.: 40H

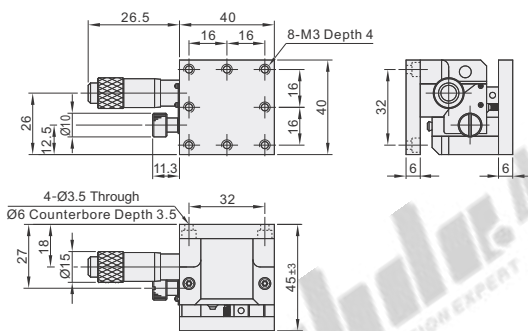

No.: 60L

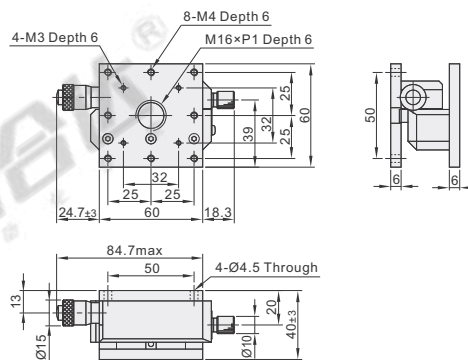

No.: 60

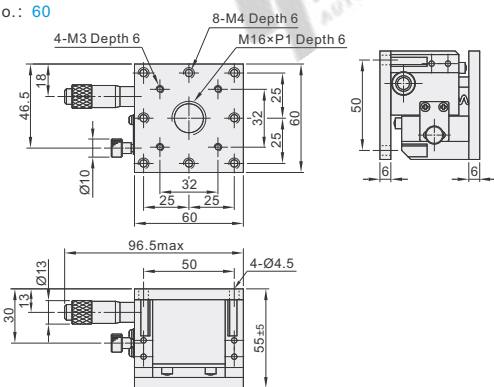

No.: 80

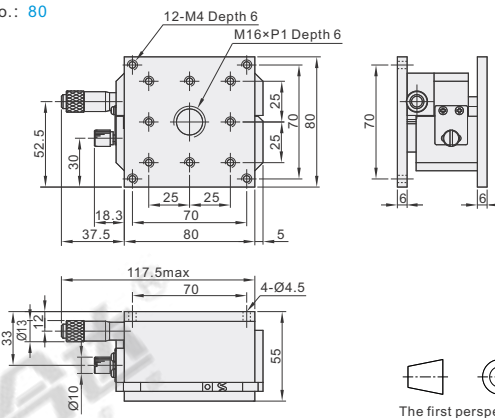

| Part Number | Code | No. | Stage Surface (mm) | Travel Distance (mm) | Minimum Graduation (µm) | Travel Accuracy (Straightness) (µm) | Load Capacity (kgf) | Body Weight (kg) |
|-------------|------|-------|--------------------|----------------------|-------------------------|-------------------------------------|---------------------|------------------|
| EJW01 | | 25 | 25×25 | ±2 | 10 | 3 | 1 | 0.06 |
| | | 40 | 40×40 | ±3 | | | | |
| | | 40H | 40×40 | ±3 | | | | |
| | | 60 | 60×60 | ±5 | | | | |
| | | 60L | 60×60 | ±3 | | | | |
| | 80 | 80×80 | ±5 | | 2 | 0.3 | | |
| | | | | | | | 3 | 1 |



| Part Number | Code | No. | Stage Surface (mm) |
|-------------|------|-----|--------------------|
| EJW01 | | 25 | 25×25 |
| EJW01-25 | | 40 | 40×40 |



| Discount price |
|----------------------------------|
| Per 1~9 10~ |
| Price 100% Additional quotation. |



Delivery
13

| Code | Type | Drive Direction | Material | Surface Treatment |
|-------|-----------------|-----------------|----------|----------------------------|
| EJE01 | Micrometer Head | X-Axis | SUS440C | Electroless Nickel Plating |



Self-made

No.: 25

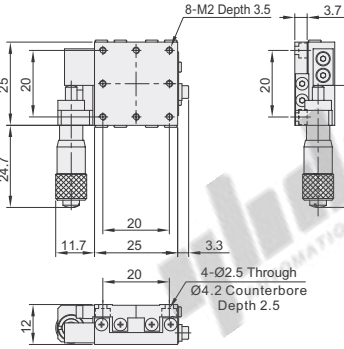

No.: 40

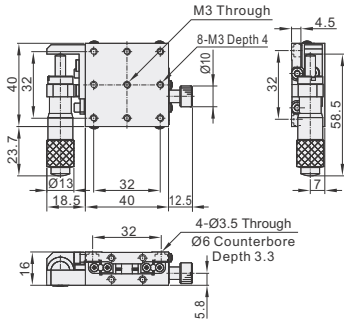

No.: 60

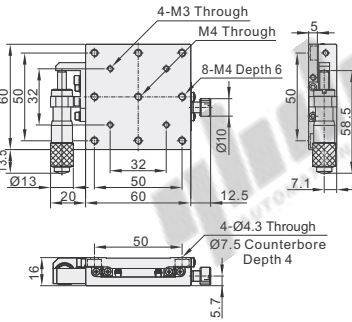

No.: 80

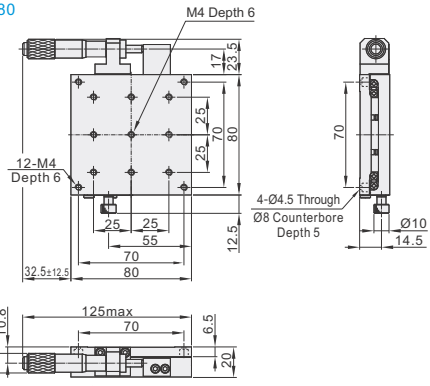

No.: 100

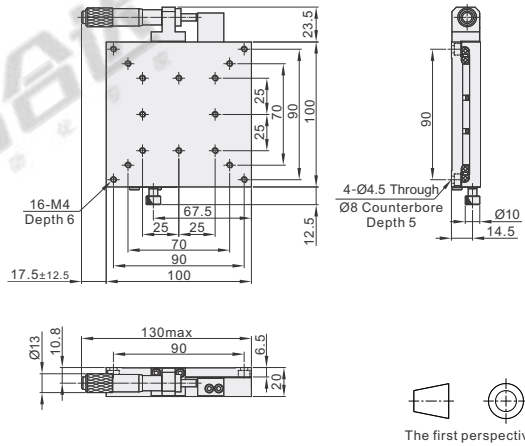

The first perspective

| Code | Part Number | Stage Surface (mm) | Travel Distance (mm) | Minimum Graduation (µm) | Travel Accuracy (Straightness) (µm) | Drive Position | Load Capacity (kgf) | Body Weight (kg) | Accessories(4 pcs) |
|-------|-------------|--------------------|----------------------|-------------------------|-------------------------------------|----------------|---------------------|------------------|---|
| | | | | | | | | | Hex Socket Head Cap Screw (Stainless Steel) |
| EJE01 | 25 | 25×25 | ±3.2 | | | | 4 | 0.07 | TAC21-M2-L8 |
| | 40 | 40×40 | ±6.5 | 10 | 3 | Side Face | 10 | 0.23 | TAC21-M3-L6 |
| | 60 | 60×60 | ±12.5 | | | | 20 | 0.4 | |
| | 80 | 80×80 | | | | | 27 | 0.9 | TAC21-M4-L6 |
| | 100 | 100×100 | | | | | 35 | 1.33 | |

| Code | QR | QU | QV | QC | CZ | T | MN |
|---------------------|---|--|--|---------------------------------------|--|---|--------------------|
| Optional Processing | Micrometer changed to left and right (reverse) position | Micrometer changed to up and down (reverse) position | Micrometer changed to up, down, left and right (reverse) position | Micrometer changed to center position | Micrometer changed to up and down (reverse) position | Opposite Clamp Bolt Enhance locking power | No Micrometer Head |
| Spec. | | | | | | | |
| | Ordering Code QR | Ordering Code QU | Ordering Code QV | Ordering Code QC | Ordering Code CZ | Ordering Code T | Ordering Code MN |
| | | ① The micrometer knob is installed on the upper part of the stage. | ① The micrometer knob is installed on the upper part of the stage. | | ① The micrometer knob is installed on the upper part of the stage. | Opposite Clamp Bolt | |



| Part Number | Stage Surface |
|-------------------|---------------|
| Code No. EJE01 40 | 40×40 |
| Code No. EJE01 60 | 60×60 |

Optional Processing

| Part Number | Optional Processing Code |
|-------------------|--------------------------|
| Code No. EJE01 40 | QR QU QC... |
| Code No. EJE01 60 | QR QU QC... |



Discount price

| Per | 1~9 | 10~ |
|-------|------|----------------------|
| Price | 100% | Additional quotation |



Delivery

| |
|----|
| 10 |
|----|



Delivery

| |
|----|
| 13 |
|----|

① No.: 25/40/60

① The Remaining

Linear Ball Guide Stages

◀ X-Axis, Pitch 0.5mm/1.0mm
High Precision, Feed Screw

Positioning Stages

| Code | Type | Drive Direction | Pitch | Material | Surface Treatment |
|-------|------------|-----------------|-------|----------|----------------------------|
| EJE11 | Feed Screw | X-Axis | 0.5 | SUS440C | Electroless Nickel Plating |
| EJE13 | | | 1.0 | | |



No.: 40

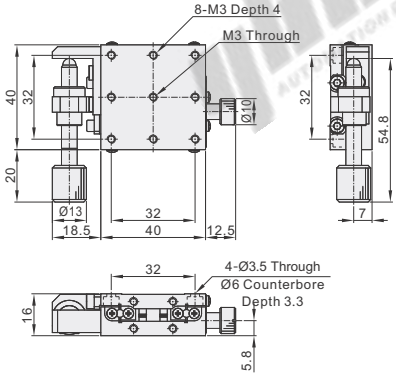

No.: 80

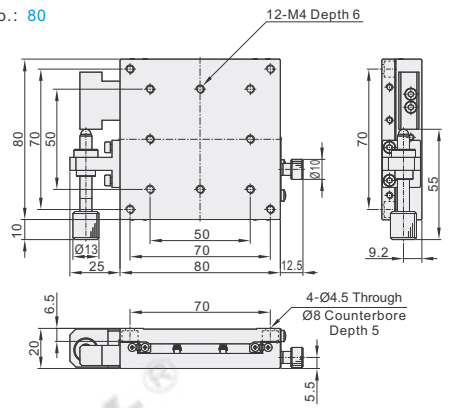

No.: 60

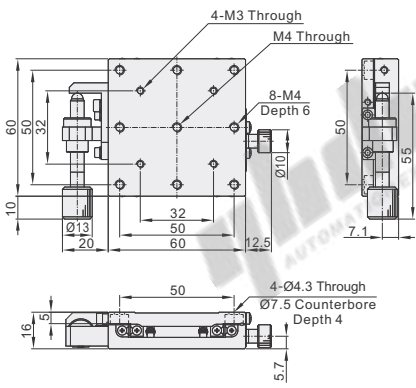

No.: 100

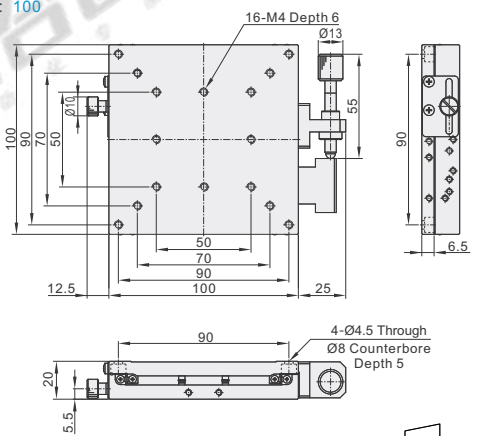

| Part Number | Code | No. | Stage Surface (mm) | Travel Distance (mm) | Load Capacity(N) | | Travel Accuracy | | | | Moment Load Capacity (N·m) | | | Moment Rigidity (N·m/cm) | | | Parallelsism (µm) | Body Weight (kg) | Accessories(4 pcs) Hex Socket Head Cap Screw (Stainless Steel) |
|----------------|------|-----|--------------------|----------------------|------------------|----------|-----------------|-------------|----------|--------|----------------------------|--------|---------|--------------------------|--------|---------|-------------------|------------------|---|
| | | | | | Horizontal | Vertical | Straightness | Parallelism | Pitching | Yawing | Pitching | Yawing | Rolling | Pitching | Yawing | Rolling | | | |
| EJE11 EJE13 | | 40 | 40×40 | ±6.5 | 98 | | | | | | 5 | 5 | 5 | 0.42 | 0.35 | 0.21 | 15 | 0.23 | TAC21-M3-L6 |
| | | 60 | 60×60 | | 196 | 49 | 1µm | 7µm | | | 10 | 10 | 9 | 0.08 | 0.08 | 0.05 | | 0.4 | |
| | | 80 | 80×80 | | 264.6 | | 3µm | 8µm | 25" | 15" | 18.2 | 18.2 | 17.7 | 0.04 | 0.04 | 0.02 | 0.84 | TAC21-M4-L6 | |
| | | 100 | 100×100 | | 343 | | | | | | 31.8 | 31.8 | 30.7 | 0.02 | 0.02 | 0.01 | 1.27 | | |

ⓘ See the previous page for optional processing.

Optional Processing

| Part Number | Code | No. | Optional Processing Code |
|-------------|------|-----|--------------------------|
| EJE11-40 | | 40 | QR QU QC... |



| Part Number | Code | No. | Stage Surface (mm) |
|-------------|------|-----|--------------------|
| EJE11-40 | | 40 | 40×40 |
| EJE11-60 | | 60 | 60×60 |

| Discount price |
|--------------------------|
| Per 1~9 |
| 10~ Additional quotation |
| Price 100% |

| Delivery |
|----------|
| 13 |

| Code | Type | Drive Direction | Material | Surface Treatment |
|-------|-----------------|-----------------|----------|----------------------------|
| EJF01 | Micrometer Head | XY-Axis | SUS440C | Electroless Nickel Plating |

No.: 25

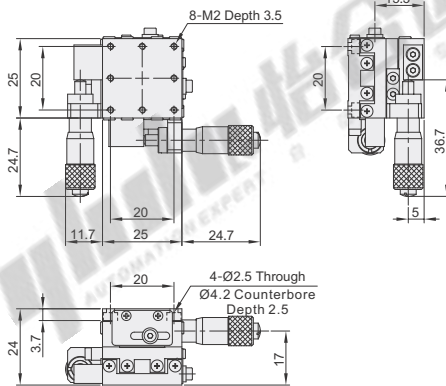

Self-made

No.: 40

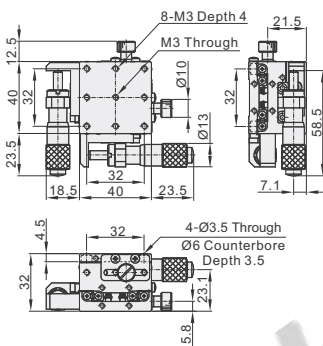

No.: 60

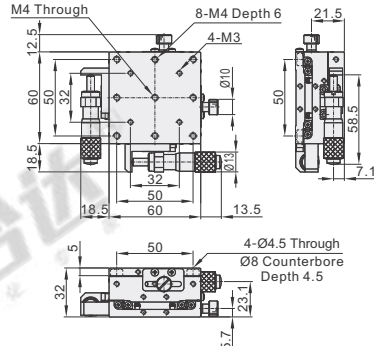

No.: 80

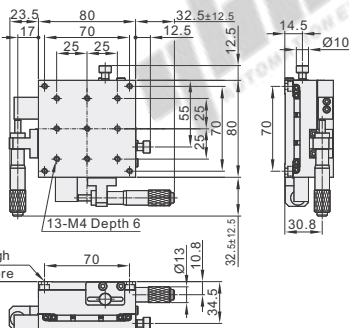

No.: 100

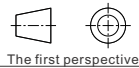
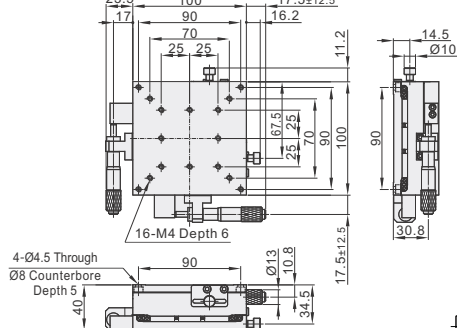

The first perspective

| Part Number | Code | No. | Stage Surface (mm) | Travel Distance (mm) | Minimum Graduation (µm) | Travel Accuracy (Straightness) (µm) | Drive Position | Load Capacity (kgf) | Body Weight (kg) | Accessories (4 pcs) |
|-------------|------|-----|--------------------|----------------------|-------------------------|-------------------------------------|----------------|---------------------|------------------|---|
| | | | | | | | | | | Hex Socket Head Cap Screw (Stainless Steel) |
| EJF01 | | 25 | 25×25 | ±3.2 | | | | 4 | 0.14 | TAC21-M2-L8 |
| | | 40 | 40×40 | ±6.5 | | 3 | | 9.7 | 0.46 | TAC21-M3-L6 |
| | | 60 | 60×60 | ±12.5 | 10 | | Side Face | 19.6 | 0.8 | |
| | | 80 | 80×80 | ±12.5 | | 5 | | 26.1 | 1.8 | TAC21-M4-L6 |
| | | 100 | 100×100 | ±12.5 | | | | 33.6 | 2.66 | |

See the next page for optional processing.



| Part Number | Code | No. | Stage Surface (mm) |
|-------------|------|-----|--------------------|
| EJF01 | 40 | 60 | 40×40 60×60 |

EJF01 - 40

Optional Processing

| Part Number | Code | No. | Optional Processing |
|-------------|------|-----|---------------------|
| EJF01 | 40 | 60 | QR |

EJF01 - 40 - QR



| Discount price |
|---------------------------------|
| Per 1~9 10- |
| Price 100% Additional quotation |

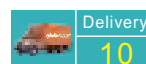

No.: 25/40/60

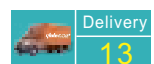

The Remaining

Linear Ball Guide Stages

XY-Axis, Thin

High Precision, Micrometer Head

Positioning Stages

| Code | Type | Drive Direction | Material | Surface Treatment |
|-------|-----------------|-----------------|----------|----------------------------|
| EJF07 | Micrometer Head | XY-Axis | SUS440C | Electroless Nickel Plating |



Self-made

No.: 40

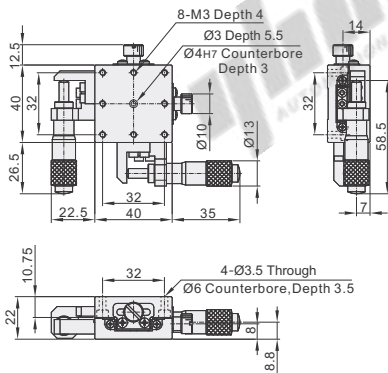

No.: 80

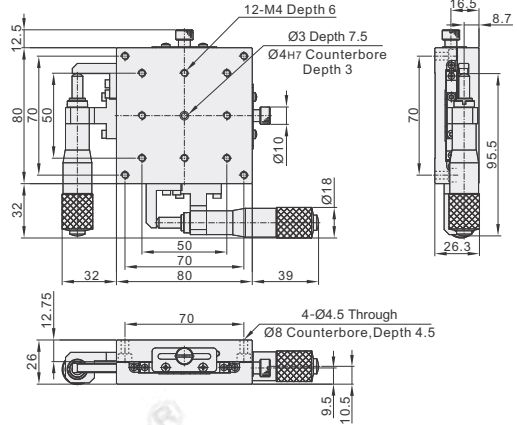

No.: 60

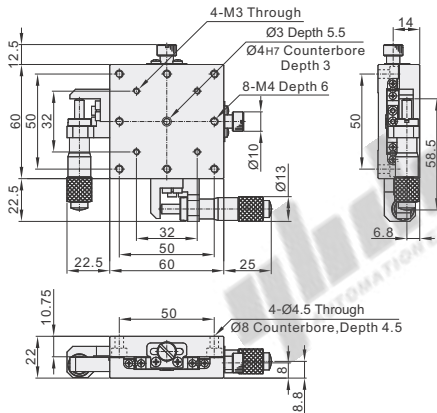

No.: 100

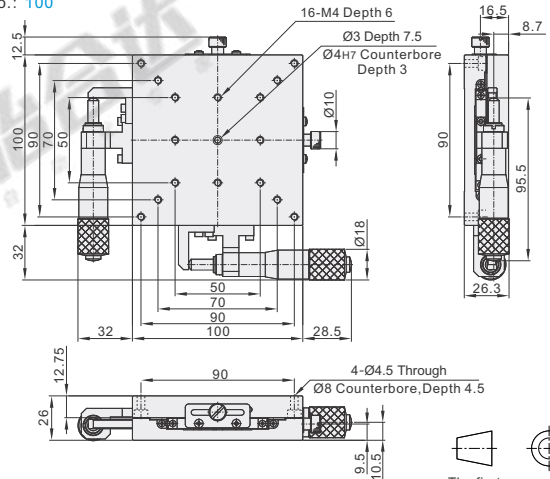

| Part Number | Code | No. | Stage Surface (mm) | Travel Distance (mm) | Minimum Graduation (µm) | Load Capacity (N) | Travel Accuracy | | | | Moment Load Capacity (N·m) | | | Moment Rigidity ("N/cm) | | | Parallellism (µm) | Body Weight (kg) | Accessories (4 pcs) |
|-------------|------|-----|--------------------|----------------------|-------------------------|-------------------|-----------------|--------------|----------|--------|----------------------------|--------|--------------|-------------------------|--------|---------|-------------------|------------------|---------------------|
| | | | | | | | Straightness | Parallellism | Pitching | Yawing | Pitching | Yawing | Rolling | Pitching | Yawing | Rolling | | | |
| EJF07 | | 40 | 40×40 | ±6.5 | 10 | 88 | 3µm | 12µm | 40" | 20" | 4.5 | 5 | 4.5 | 0.8 | 0.68 | 0.85 | 50 | 0.34 | TAC21-M3-L10 |
| | | 60 | 60×60 | | | 186 | | | | | 9 | 8.1 | 9 | 0.21 | 0.19 | 0.2 | | 0.64 | |
| | | 80 | 80×80 | ±12.5 | 196 | 16.4 | 15.9 | 16.4 | 0.09 | 0.06 | 0.08 | 1.32 | TAC21-M4-L10 | | | | | | |
| | | 100 | 100×100 | | 245 | 27.6 | 28.6 | 27.6 | 0.06 | 0.03 | 0.06 | 2 | | | | | | | |



| Code | QR | QC |
|-------|---|---------------------------------------|
| | Micrometer changed to left and right (reverse) position | Micrometer changed to center position |
| | Ordering Code: QR | Ordering Code: QC |
| Spec. | | |



| Part Number | Code | No. | Stage Surface (mm) |
|-------------|------|-----|--------------------|
| EJF07 | 40 | 40 | 40×40 |
| EJF07 | 60 | 60 | 60×60 |

EJF07 - 40

Optional Processing

| Part Number | Code | No. | Optional Processing Code |
|-------------|------|-----|--------------------------|
| EJF07 | 40 | 40 | QR QC |
| EJF07 | 60 | 60 | QR QC |

EJF07 - 40 - QR



| Per | 1~9 | 10~ |
|-------|------|----------------------|
| Price | 100% | Additional quotation |



13

Linear Ball Guide Stages

XY-Axis, Thin

High Precision, Feed Screw

Positioning Stages

| Code | Type | Drive Direction | Material | Surface Treatment |
|-------|------------|-----------------|----------|----------------------------|
| EJF17 | Feed Screw | XY-Axis | SUS440C | Electroless Nickel Plating |



No.: 40

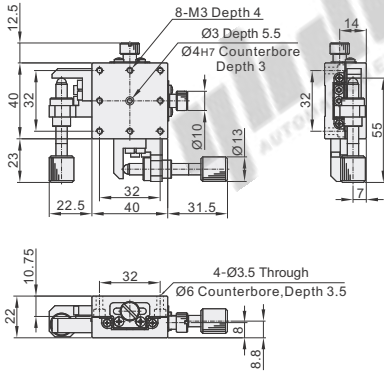

No.: 80

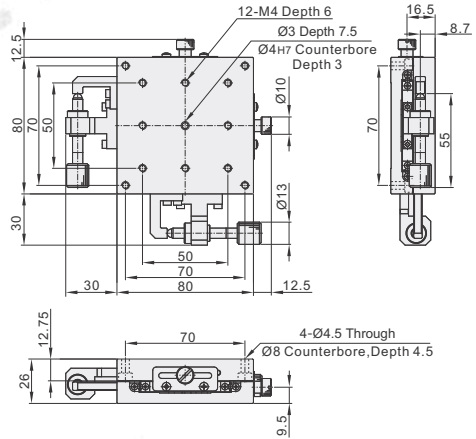

No.: 60

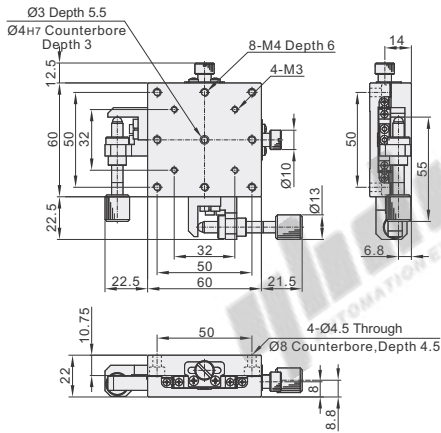

No.: 100

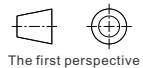
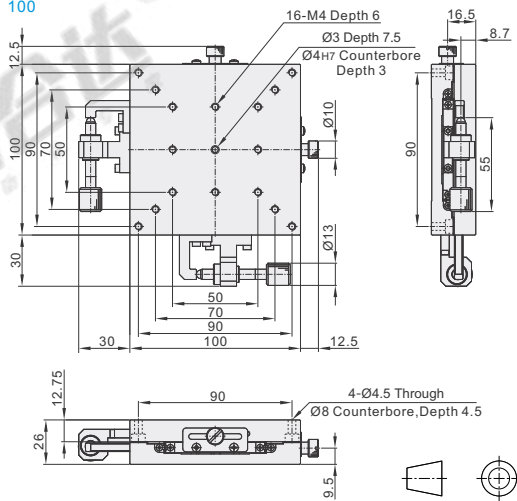

| Part Number Code | Stage Surface No. | Travel Distance (mm) | Minimum Graduation (µm) | Load Capacity (N) | Travel Accuracy | | | | Moment Load Capacity (N·m) | | | Moment Rigidity (N/cm) | | | Parallelism (µm) | Body Weight (kg) | Accessories (4 pcs) |
|------------------|-------------------|----------------------|-------------------------|-------------------|-----------------|-------------|----------|--------|----------------------------|--------|---------|------------------------|--------|---------|------------------|------------------|---------------------|
| | | | | | Straightness | Parallelism | Pitching | Yawing | Pitching | Yawing | Rolling | Pitching | Yawing | Rolling | | | |
| EJF17 | 40 | 40×40 | ±6.5 | 88 | 3µm | 12µm | 40" | 20" | 4.5 | 5 | 4.5 | 0.8 | 0.68 | 0.85 | 30 | 0.34 | TAC21-M3-L10 |
| | 60 | 60×60 | | 186 | | | | | 9 | 8.1 | 9 | 0.21 | 0.19 | 0.2 | | 0.64 | |
| | 80 | 80×80 | | 196 | | 15µm | 16.4 | 15.9 | 16.4 | 0.09 | 0.06 | 0.08 | 40 | 1.32 | TAC21-M4-L10 | | |
| | 100 | 100×100 | | 245 | | | 27.6 | 28.6 | 27.6 | 0.06 | 0.03 | 0.06 | | 2 | | | |



Optional Processing

| Code | QR | QC |
|-------|---|---|
| Spec. | <p>Feed Screw changed to left and right (reverse) position</p> <p>Ordering Code: QR</p> | <p>Feed Screw changed to center position</p> <p>Ordering Code: QC</p> |



Please order as shown

| Part Number Code | Stage Surface No. |
|------------------|-------------------|
| EJF17 | 40 |
| EJF17 | 60 |

EJF17 - 40

Optional Processing

| Part Number Code | Optional Processing Code |
|------------------|--------------------------|
| EJF17 | QR |
| EJF17 | QC |

EJF17 - 40 - QR



Discount price

| Per Price | 1~9 | 10~ |
|-----------|----------------------|-----|
| 100% | Additional quotation | |



Delivery 13

| Code | Type | Drive Direction | Material | Surface Treatment |
|-------|-----------------|-----------------|----------|----------------------------|
| EJG01 | Micrometer Head | Z-Axis | SUS440C | Electroless Nickel Plating |

No.: 25

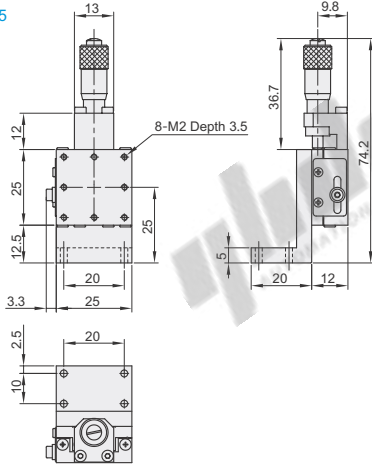

No.: 40

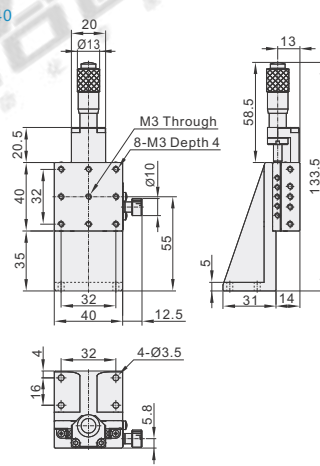

No.: 60

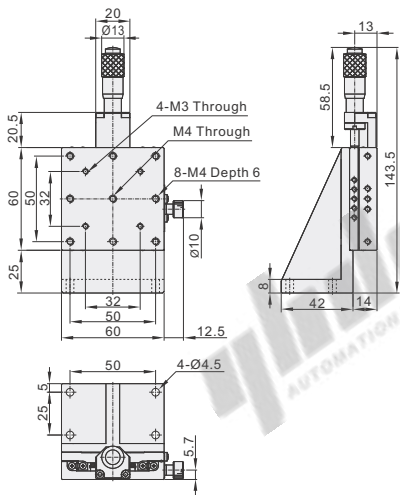

No.: 80

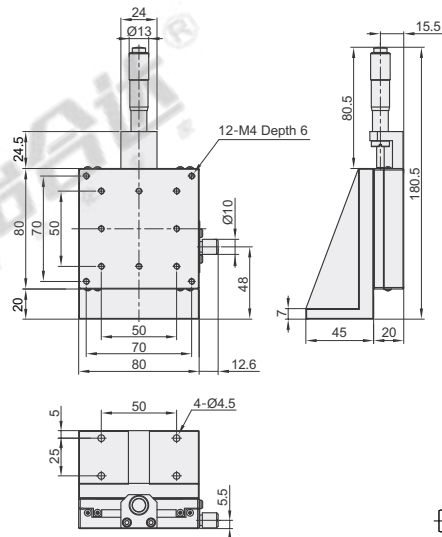

Self-made

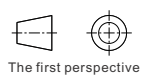

The first perspective

| Part Number | Code | Stage Surface (mm) | Travel Distance (mm) | Minimum Graduation (μm) | Load Capacity (N) | Travel Accuracy | | | Moment Load Capacity (N·m) | | | Moment Rigidity (N/cm) | | | Body Weight (kg) | Accessories (4 pcs) Hex Socket Head Cap Screw (Stainless Steel) |
|-------------|------|--------------------|----------------------|-------------------------|-------------------|-----------------|----------|--------|----------------------------|--------|---------|------------------------|--------|---------|------------------|--|
| | | | | | | Straightness | Pitching | Yawing | Pitching | Yawing | Rolling | Pitching | Yawing | Rolling | | |
| EJG01 | 25 | 25×25 | ±3.2 | | 9.8 | | 30" | 25" | 2 | 2 | 3.5 | 1.9 | 1.1 | 1.1 | 0.09 | TAC21-M2-L8 |
| | 40 | 40×40 | ±6.5 | 10 | | 3μm | | | 5 | 5 | 5 | 0.42 | 0.35 | 0.21 | 0.32 | TAC21-M3-L10 |
| | 60 | 60×60 | | | 49 | | 25" | 15" | 10 | 10 | 9 | 0.08 | 0.08 | 0.05 | 0.58 | TAC21-M4-L12 |
| | 80 | 80×80 | ±12.5 | | | | | | 18.2 | 18.2 | 17.7 | 0.04 | 0.04 | 0.02 | 1.2 | |



QR

Micrometer changed to the left position (knob facing down)

Ordering Code | QR

Spec.

QL

Micrometer changed to the right position (knob facing down)

Ordering Code | QL



| Part Number | Code | Stage Surface (mm) |
|-------------|------|--------------------|
| EJG01 | 40 | 40×40 |
| EJG01 | 60 | 60×60 |

EJG01-40

Optional Processing

| Part Number | Code | Optional Processing Code |
|-------------|------|--------------------------|
| EJG01 | 40 | QR QL |
| EJG01 | 60 | QR QL |

EJG01-40-QR

Delivery 10

No.: 25/40/60

Delivery 13

The Remaining

Linear Ball Guide Stages

Z-Axis

High Precision, Feed Screw

Positioning Stages

| Code | Type | Drive Direction | Material | Surface Treatment |
|-------|------------|-----------------|----------|----------------------------|
| EJG11 | Feed Screw | Z-Axis | SUS440C | Electroless Nickel Plating |

No.: 40

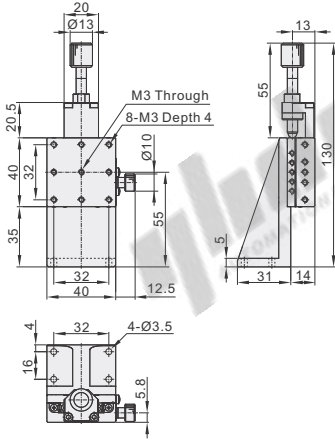

No.: 80

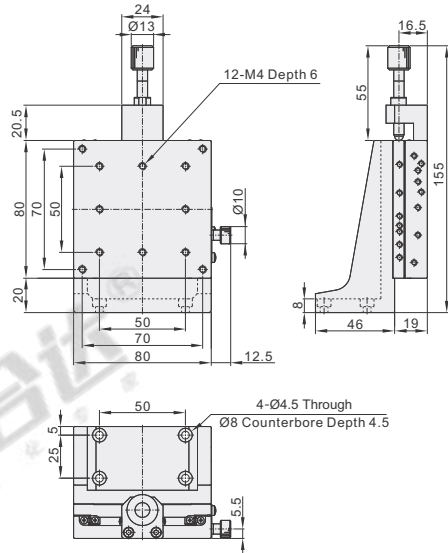

No.: 60

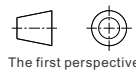
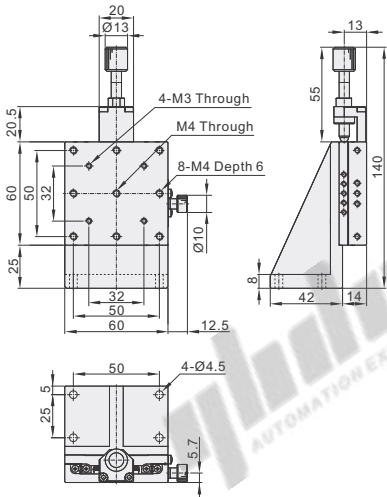

| Part Number | Stage Surface (mm) | Travel Distance (mm) | Load Capacity (N) | Travel Accuracy | | | Moment Load Capacity (N·m) | | | Moment Rigidity (1"/N·cm) | | | Body Weight (kg) | Accessories (4 pcs) Hex Socket Head Cap Screw (Stainless Steel) | |
|-------------|--------------------|----------------------|-------------------|-----------------|----------|--------|----------------------------|--------|---------|---------------------------|--------|---------|------------------|--|--------------|
| | | | | Straightness | Pitching | Yawing | Pitching | Yawing | Rolling | Pitching | Yawing | Rolling | | | |
| EJG11 | 40 | 40×40 | | | | | 5 | 5 | 5 | 0.42 | 0.35 | 0.21 | 0.32 | TAC21-M3-L10 | |
| | 60 | 60×60 | ±6.5 | 49 | 1µm | 25" | 15" | 10 | 10 | 9 | 0.08 | 0.08 | 0.05 | 0.58 | TAC21-M4-L12 |
| | 80 | 80×80 | | | | | 18.2 | 18.2 | 17.7 | 0.04 | 0.04 | 0.02 | 1.2 | | |



| Code | QR | QL | QN |
|-------|--|---|---|
| Spec. | <p>Change the feed screw to the left position (knob facing down)</p> <p>Ordering Code QR</p> | <p>Change the feed screw to the right position (knob facing down)</p> <p>Ordering Code QL</p> | <p>Change the feed screw to the right position (knob facing up)</p> <p>Ordering Code QN</p> |



| Part Number | Code | No. | Stage Surface (mm) |
|-------------|------|-----|--------------------|
| EJG11 | QR | 40 | 40×40 |
| EJG11 | QR | 60 | 60×60 |

Optional Processing

| Part Number | Code | No. | Optional Processing Code |
|-------------|------|-----|--------------------------|
| EJG11 | QR | 40 | QR QL QN |
| EJG11 | QR | 60 | QR QL QN |

EJG11-40-QR EJG11-40-QL EJG11-40-QN



Discount price

| Per | 1~9 | 10~ |
|-------|------|----------------------|
| Price | 100% | Additional quotation |



Delivery

| |
|----|
| 13 |
|----|

X-Axis, Pitch 0.8/4.0 mm ▶

High Precision, Feed Screw

Dovetail Groove Stages

| Code | Type | Drive Direction | Pitch | Material | Surface Treatment |
|-------|------------|-----------------|-------|----------------|-------------------|
| EJK11 | Feed Screw | X-Axis | 4.0 | Aluminum Alloy | Black Anodize |
| EJK12 | | | 0.8 | | |



No.: 40

No.: 60

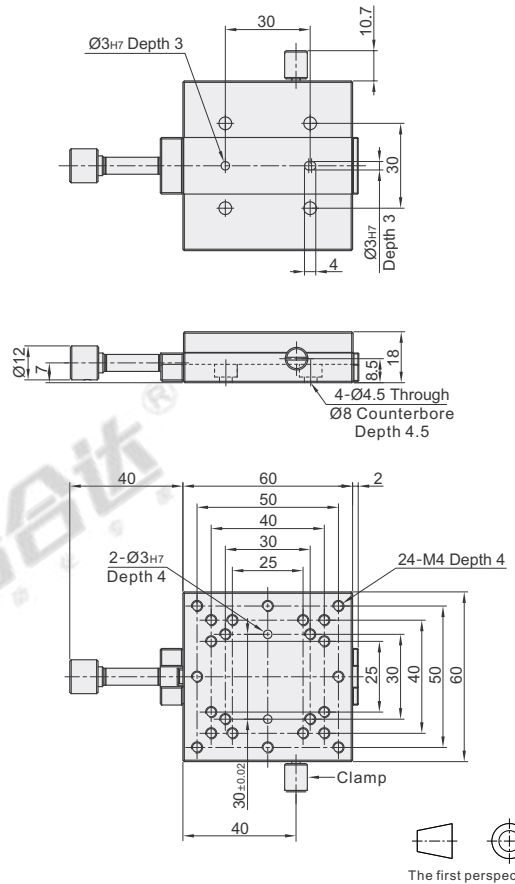
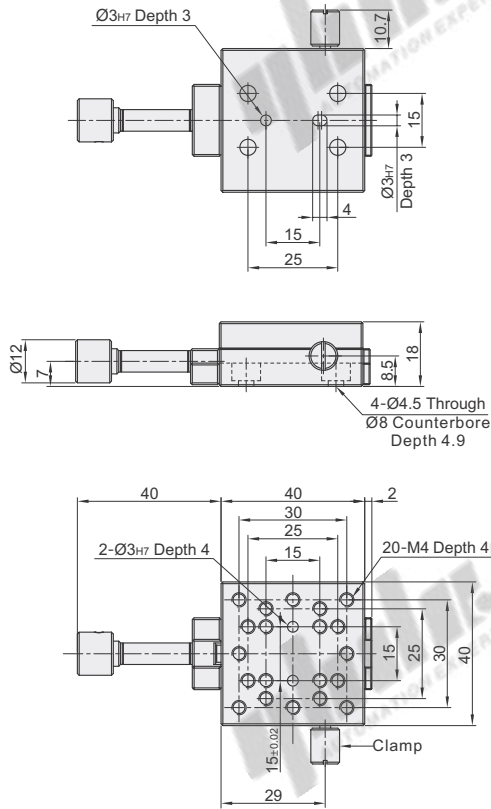

| Part Number | | Stage Surface (mm) | Travel Distance (mm) | Minimum Graduation (mm) | Load Capacity(N) | | Travel Accuracy(μm) | | Body Weight (kg) | Accessories(4 pcs) Hex Socket Head Cap Screw (Stainless Steel) |
|-------------|-----|--------------------|----------------------|-------------------------|------------------|----------|---------------------|-------------|------------------|---|
| Code | No. | | | | Horizontal | Vertical | Straightness | Parallelism | | |
| EJK11 | 40 | 40×40 | ±11 | 0.1 | 19.6 | 9.8 | 20 | 30 | 0.1 | TAC21-M4-L5 |
| EJK12 | 60 | 60×60 | ±21 | | 29.4 | 14.7 | | | 0.19 | |



| Part Number | |
|-------------|-----|
| Code | No. |
| EJK11 | 40 |
| EJK12 | 60 |

EJK11-40

Optional Processing

| Part Number | | Optional Processing |
|-------------|-----|---------------------|
| Code | No. | Code |
| EJK11 | 40 | QR |
| EJK12 | 60 | QR |

EJK11-40-QR



| Code | QR |
|-------|---|
| | Feed screw position change: Right side (Ordering Code) QR |
| Spec. | |



| Discount price | | |
|----------------|------|----------------------|
| Per | 1~9 | 10~ |
| Price | 100% | Additional Quotation |



| Delivery | |
|----------|----|
| | 10 |

Dovetail Groove Stages

XY-Axis

High Precision, Feed Screw

Positioning Stages

| Code | Type | Drive Direction | Material | Surface Treatment |
|-------|------------|-----------------|----------------|--------------------|
| EJK01 | Feed Screw | XY-Axis | Copper Alloy | Black Fluoro Resin |
| EJK02 | | | Aluminum Alloy | Black Anodize |



Self-made

No.: 25

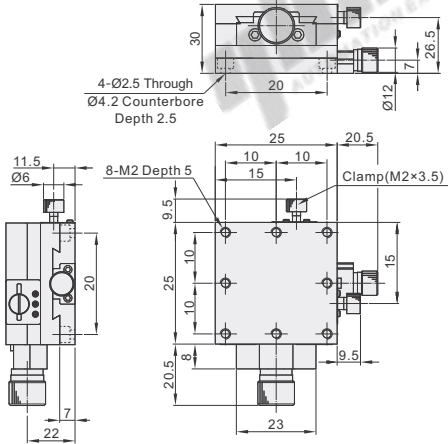

No.: 40

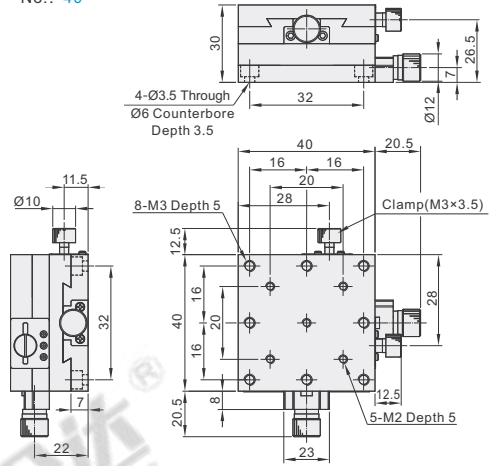

① EJK02-40 without central threaded hole.

No.: 60

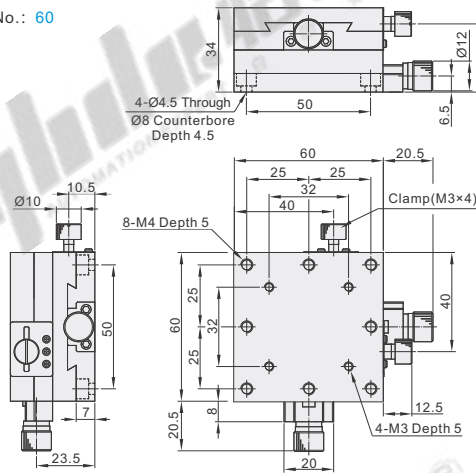

| Part Number | Code | No. | Stage Surface (mm) | Travel Distance (mm) | Minimum Graduation (mm) | Travel per Rotation (mm) | Load Capacity (N) | Travel Accuracy | | | XY-Axis Orthogonality (µm) | Body Weight (kg) | Accessories (4 pcs) Hex Socket Head Cap Screw (Stainless Steel) |
|-------------|------|-----|--------------------|----------------------|-------------------------|--------------------------|-------------------|-------------------|----------|--------|----------------------------|------------------|--|
| | | | | | | | | Straightness (µm) | Pitching | Yawing | | | |
| EJK01 | | 25 | 25x25 | ±5 | | | 28.4 | 1.3 | 1.5 | 1.3 | | 0.15 | TAC21-M2-L8 |
| EJK02 | | 40 | 40x40 | ±7 | 0.1 | 0.5 | 27.4 | 30 | 3 | 3 | 70 | 0.38 | TAC21-M3-L6 |
| | | 60 | 60x60 | ±8 | | | 33.3 | | 4 | 4 | | 1.2 | TAC21-M4-L6 |



| Part Number | | Stage Surface (mm) |
|-------------|-----|--------------------|
| Code | No. | |
| EJK01 | 25 | 25x25 |
| EJK02 | 40 | 40x40 |

EJK01-25



| Discount price | | |
|----------------|------|----------------------|
| Per | 1~9 | 10~ |
| Price | 100% | Additional quotation |



| Delivery | |
|----------|----|
| | 10 |

| Code | Type | Drive Direction | Material | Surface Treatment |
|-------|------------|-----------------|--------------|--------------------|
| EJL01 | Feed Screw | Z-Axis | Copper Alloy | Black Fluoro Resin |



Self-made

No.: 25

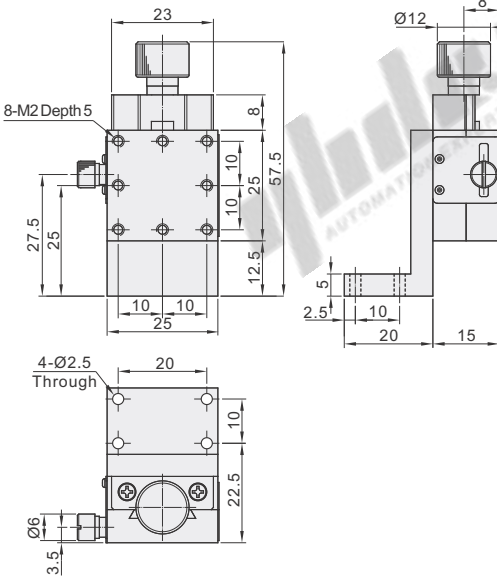

No.: 60

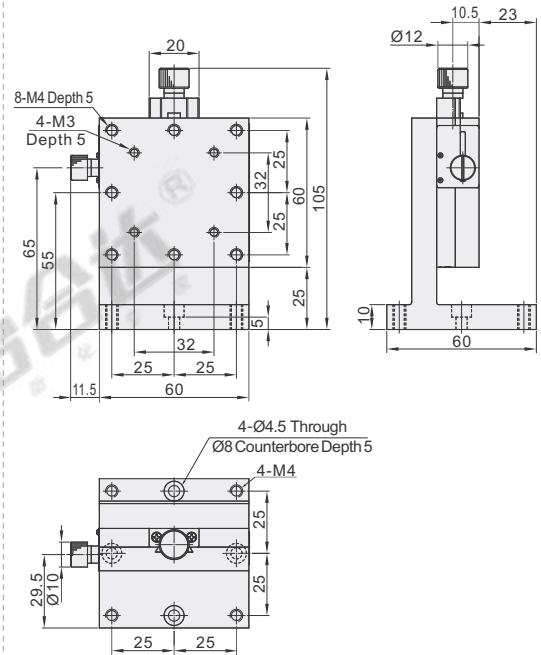

No.: 40

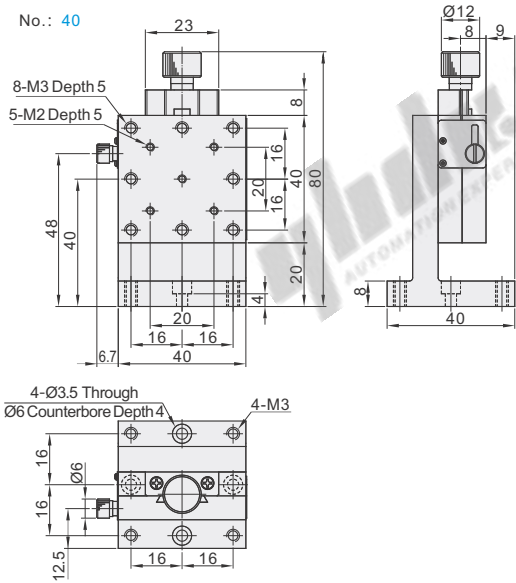

| Part Number | | Stage Surface (mm) | Travel Distance (mm) | Minimum Graduation (mm) | Travel Accuracy (Straightness) (µm) | Load Capacity (kgf) | Body Weight (kg) |
|-------------|-----|--------------------|----------------------|-------------------------|-------------------------------------|---------------------|------------------|
| Code | No. | | | | | | |
| EJL01 | 25 | 25×25 | ±3 | 0.1 | 30 | 1.0 | 0.09 |
| | 40 | 40×40 | ±7 | | | | |
| | 60 | 60×60 | ±9 | | | | |



| Part Number | | Stage Surface |
|-------------|-----|---------------|
| Code | No. | (mm) |
| EJL01 | 25 | 25×25 |
| | 40 | 40×40 |

EJL01-25



| Discount price | |
|----------------|----------------------|
| Per | Price |
| 1-9 | 100% |
| 10- | Additional quotation |



| Delivery |
|----------|
| 10 |

Dovetail Groove Stages

Z-Axis

High Precision, Feed Screw

Positioning Stages

| Code | Type | Drive Direction | Material | | Surface Treatment |
|-------|------------|-----------------|-----------|-----------------|-------------------|
| | | | Main Body | Feed Screw | |
| EJL06 | Feed Screw | Z-Axis | Aluminum | Stainless Steel | Black Anodize |

No.: 25

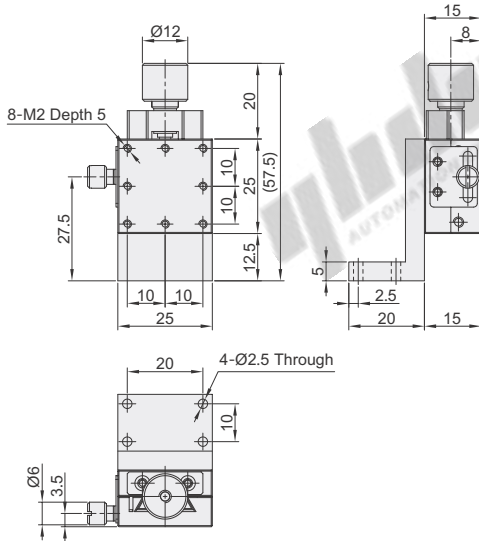

No.: 60

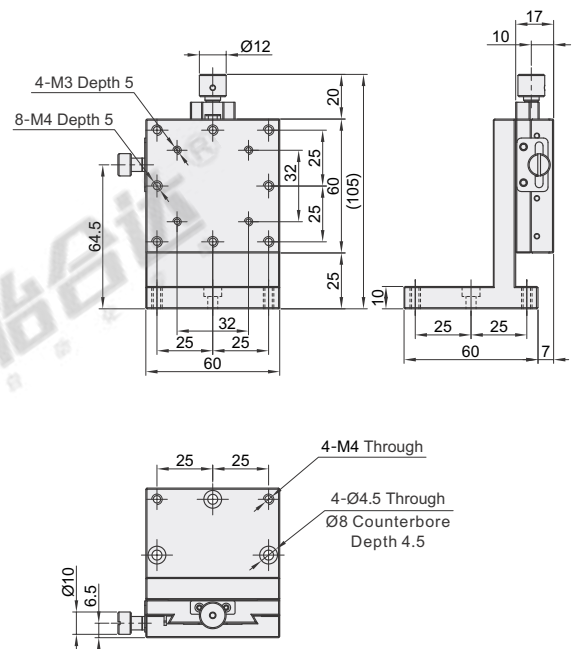

No.: 40

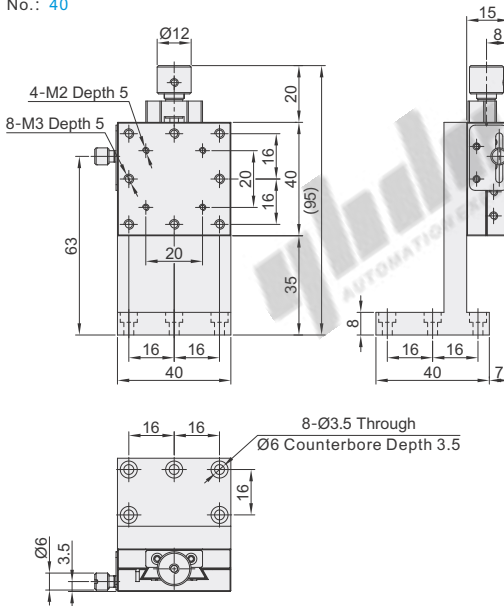

Self-made

| Part Number | | Stage Surface (mm) | Travel Distance (mm) | Minimum Graduation (mm) | Travel Accuracy (Straightness) (μm) | Load Capacity (kgf) | Body Weight (kg) |
|-------------|-----|--------------------|----------------------|-------------------------|-------------------------------------|---------------------|------------------|
| Code | No. | | | | | | |
| EJL06 | 25 | 25×25 | ±5 | 0.1 | 30 | 1 | 0.06 |
| | 40 | 40×40 | ±7 | | | | |
| | 60 | 60×60 | ±9 | | | | |



| Part Number | | Stage Surface (mm) |
|-------------|-----|--------------------|
| Code | No. | |
| EJL06 | 25 | 25×25 |
| | 40 | 40×40 |

EJL06-25



| Discount price | | |
|----------------|------|----------------------|
| Per | 1~9 | 10~ |
| Price | 100% | Additional quotation |



| Delivery | |
|----------|----|
| | 10 |

| Code | Type | Drive Direction | Material | Surface Treatment |
|-------|--------------------|-----------------|----------------|-------------------|
| EJN01 | Rack & Pinion Feed | X-Axis | Aluminum Alloy | Black Anodize |



Self-made

No.: 40

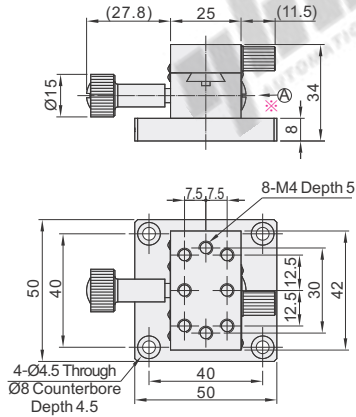

No.: 60

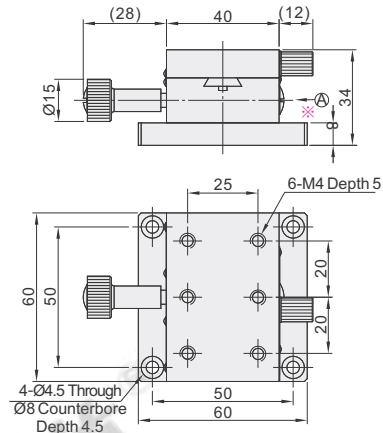

No.: 90

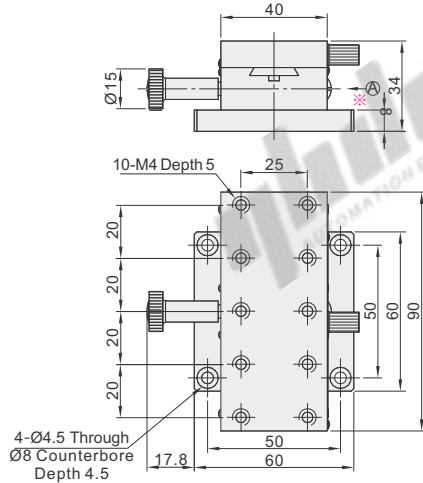

No.: 140

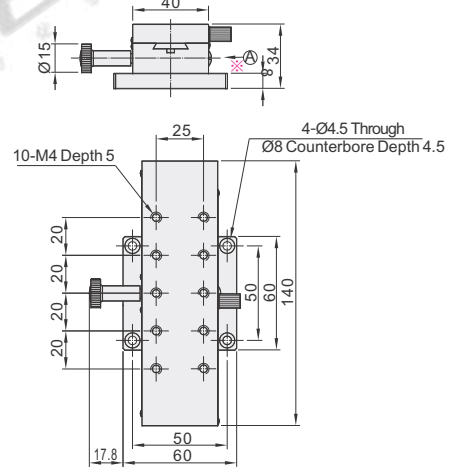

※By turning the preload adjustment screw (A) clockwise with a flathead screwdriver, the stage slides slowly, and by turning counterclockwise the stage slides quickly and smoothly.

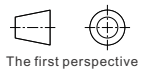

| Part Number | | Stage Surface (mm) | Travel Distance (mm) | Minimum Graduation (mm) | Travel Accuracy (Straightness) (μm) | Load Capacity (kgf) | Body Weight (kg) |
|-------------|-----|--------------------|----------------------|-------------------------|-------------------------------------|---------------------|------------------|
| Code | No. | | | | | | |
| EJN01 | 40 | 25×42 | ±12 | 0.1 | 30 | 3.0 | 0.17 |
| | 60 | 40×60 | ±21 | | | | 0.29 |
| | 90 | 40×90 | ±35 | | | | 0.4 |
| | 140 | 40×140 | ±60 | | | | 0.56 |



| Part Number | | Stage Surface (mm) |
|-------------|-----|--------------------|
| Code | No. | |
| EJN01 | 40 | 25×42 |
| EJN01 | 60 | 40×60 |



| Discount price | |
|----------------|--------------------------|
| Per | 1~9 10~ |
| Price | 100% Additional discount |



X-Axis, Clamp Reinforcement ▶

High Precision, Rack & Pinion Feed

Dovetail Groove Stages

| Code | Type | Drive Direction | Material | Surface Treatment |
|-------|---|-----------------|----------------|-------------------|
| EJN21 | Rack & Pinion Feed Clamp Reinforcement | X-Axis | Aluminum Alloy | Black Anodize |



No.: 40

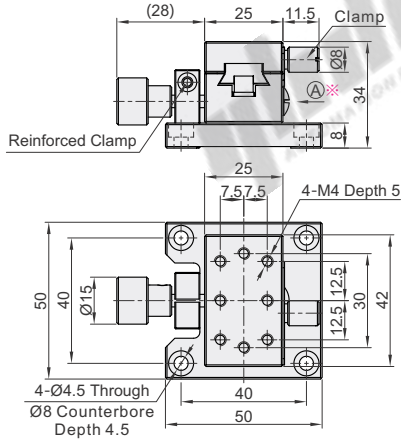

No.: 60

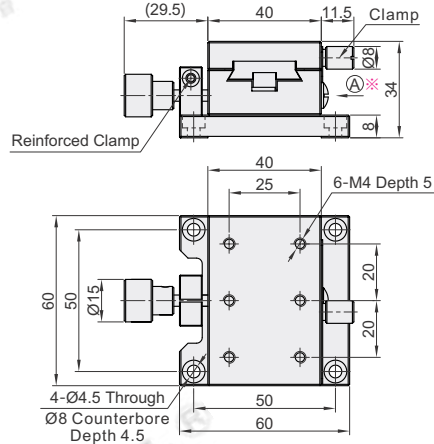

No.: 90

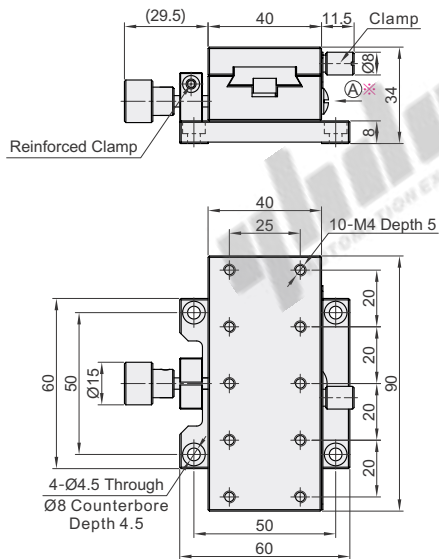

No.: 140

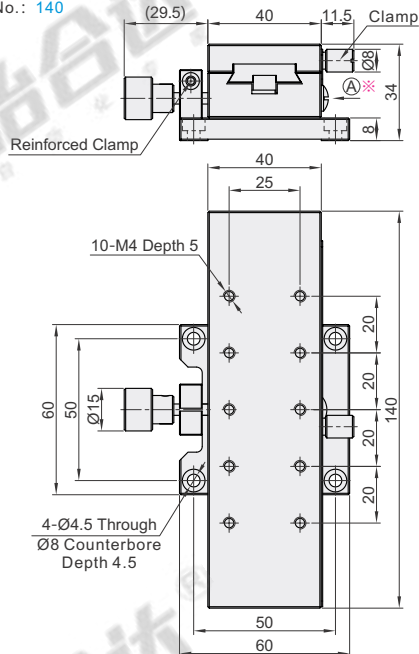

※By turning the preload adjustment screw (A) clockwise with a flathead screwdriver, the stage slides slowly, and by turning counterclockwise the stage slides quickly and smoothly.



| Part Number | | Stage Surface (mm) | Travel Distance (mm) | Minimum Graduation (mm) | Travel Accuracy (Straightness) (μm) | Load Capacity (kgf) | Body Weight (kg) |
|-------------|-----|--------------------|----------------------|-------------------------|-------------------------------------|---------------------|------------------|
| Code | No. | | | | | | |
| EJN21 | 40 | 25×42 | ±12 | 0.1 | 30 | 3 | 0.17 |
| | 60 | 40×60 | ±21 | | | | |
| | 90 | 40×90 | ±35 | | | | |
| | 140 | 40×140 | ±60 | | | | |



| Part Number | | Stage Surface (mm) |
|-------------|-----|--------------------|
| Code | No. | |
| EJN21 | 40 | 25×42 |
| | 60 | 40×60 |

EJN21-40



| Discount price | | |
|----------------|------|----------------------|
| Per | 1~9 | 10~ |
| Price | 100% | Additional quotation |

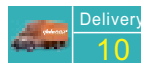

Dovetail Groove Stages

◀ X-Axis, High Load Capacity
High Precision, Rack & Pinion Feed

Positioning Stages

| Code | Type | Drive Direction | Material | Surface Treatment |
|-------|--|-----------------|----------|----------------------------|
| EJN31 | Rack & Pinion Feed High Load Capacity | X-Axis | S45C | Electroless Nickel Plating |



No.: 40

No.: 60

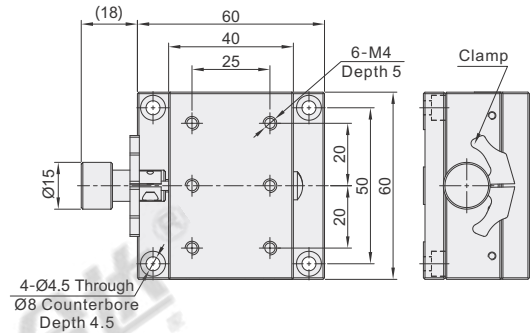
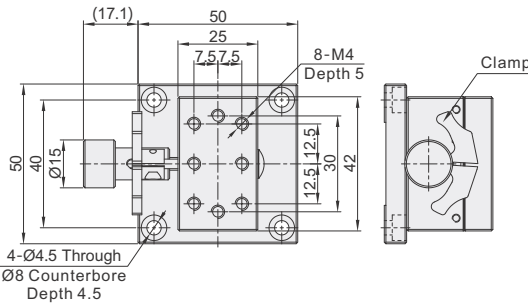
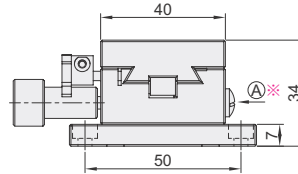
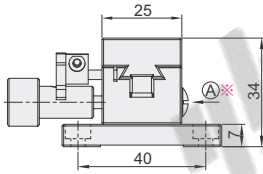

No.: 90

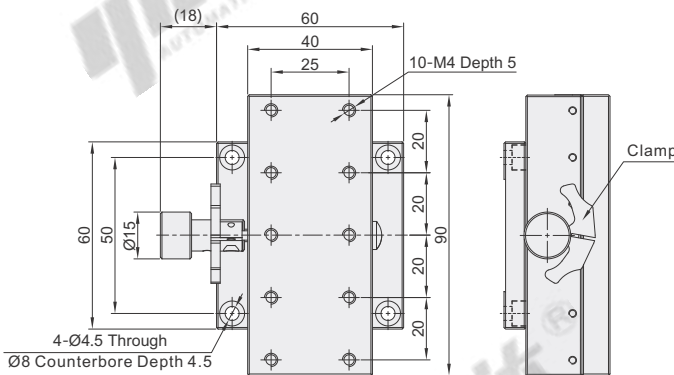
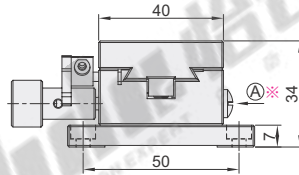

※By turning the preload adjustment screw (A) clockwise with a flathead screwdriver, the stage slides slowly, and by turning counterclockwise the stage slides quickly and smoothly.



| Part Number | | Stage Surface (mm) | Travel Distance (mm) | Travel per Rotation (mm) | Minimum Graduation (mm) | Travel Accuracy | | Load Capacity (kgf) | BodyWeight (kg) |
|-------------|-----|--------------------|----------------------|--------------------------|-------------------------|------------------|-----------------|---------------------|-----------------|
| Code | No. | | | | | Straightness(μm) | Parallelism(μm) | | |
| EJN31 | 40 | 25×42 | ±12 | 18 | 0.1 | 30 | 50 | 9.8 | 0.35 |
| | 60 | 40×60 | ±21 | | | | | 19.6 | 0.68 |
| | 90 | 40×90 | ±35 | | | | | 29.4 | 0.93 |



| Part Number | Stage Surface (mm) |
|-------------|--------------------|
| Code No. | No. |
| EJN31 | 40 |
| | 60 |

EJN31-40



| Discount price | | |
|----------------|------|----------------------|
| Per | 1~9 | 10~ |
| Price | 100% | Additional quotation |

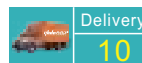

Dovetail Groove Stages

◀ Z-Axis

High Precision, Rack & Pinion Feed

Positioning Stages

EJQ

| Code | Type | Drive Direction | Material | Surface Treatment |
|-------|--------------------|-----------------|----------------|-------------------|
| EJQ01 | Rack & Pinion Feed | Z-Axis | Aluminum Alloy | Black Anodize |

No.: 40

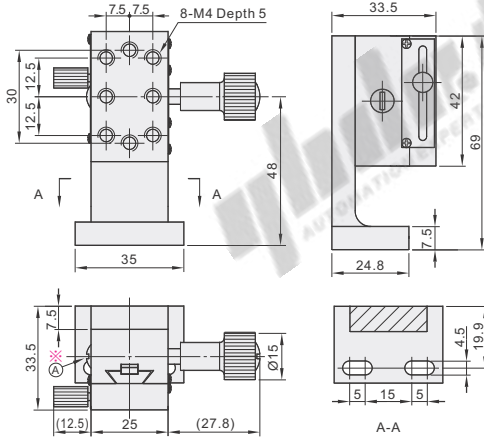

No.: 60

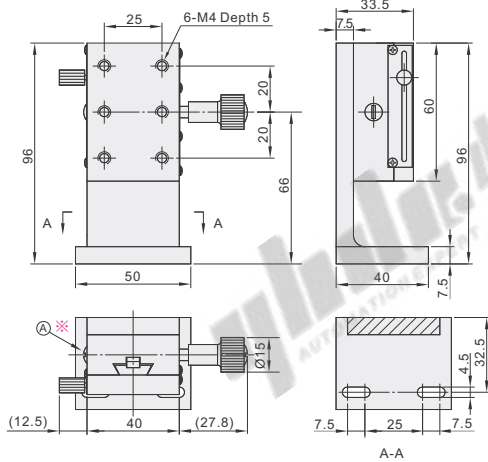

No.: 90

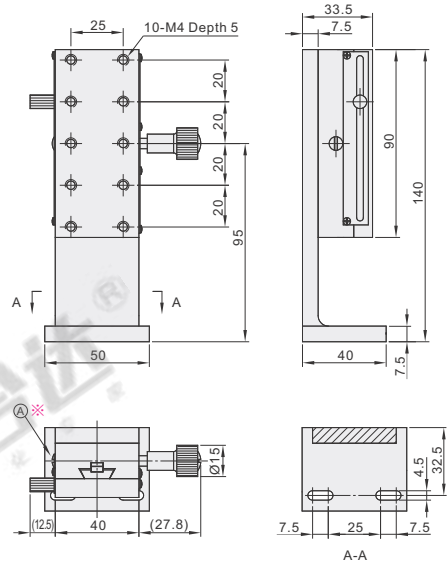

Self-made



※By turning the preload adjustment screw (A) clockwise with a flathead screwdriver, the stage slides slowly, and by turning counterclockwise the stage slides quickly and smoothly.

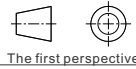

| Part Number | | Stage Surface (mm) | Travel Distance (mm) | Minimum Graduation (mm) | Travel Accuracy (Straightness) (μm) | Load Capacity (kgf) | Body Weight (kg) |
|-------------|-----|--------------------|----------------------|-------------------------|-------------------------------------|---------------------|------------------|
| Code | No. | | | | | | |
| | 40 | 25×42 | ±12 | 0.1 | 30 | 1.5 | 0.17 |
| | 60 | 40×60 | ±21 | | | | 0.33 |
| EJQ01 | 90 | 40×90 | ±35 | | | 2.0 | 0.45 |



Please order as shown

| Part Number | | Stage Surface (mm) |
|-------------|-----|--------------------|
| Code | No. | |
| EJQ01 | 40 | 25×42 |
| | 60 | 40×60 |

EJQ01-40



| Discount price | | |
|----------------|------|----------------------|
| Per | 1~9 | 10~ |
| Price | 100% | Additional quotation |



| Delivery | |
|----------|--|
| 10 | |

X-Axis/Z-Axis

High Precision, Long Stroke, Rack & Pinion Long Stroke

Dovetail Groove Stages

Positioning Stages
E8

X-Axis

| Code | Type | Drive Direction | Material | Surface Treatment |
|-------|---------------------------|-----------------|----------------|-------------------|
| EJR01 | Rack & Pinion Long Stroke | X-Axis | Aluminum Alloy | Black Anodize |

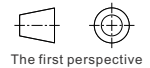
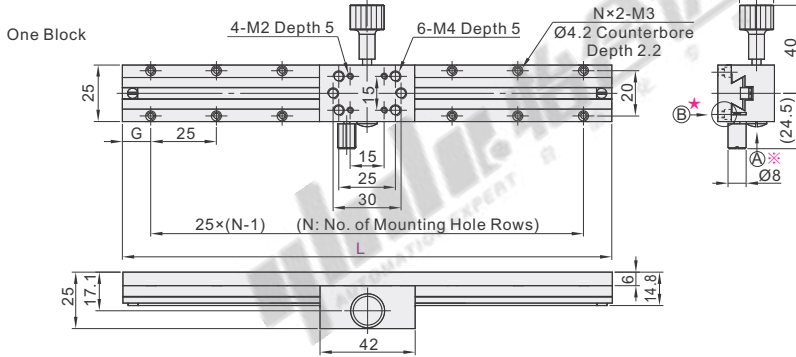

Two Blocks

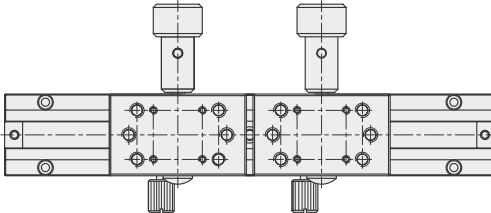

Mounting Hole Enlarged View

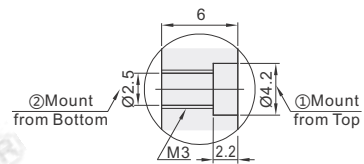

※ By turning the preload adjustment screw (A) clockwise with a flathead screw driver, the stage slides slowly. By turning counterclockwise, the slides quickly and smoothly.
 ① The product can choose two blocks, but the stroke should reduce the length of the corresponding blocks, and the total length of the slider cannot be greater than its own stroke.

①Mount from Top: Use M2 Screws.
 ②Mount from Bottom: Use M3 Screws.

| Part Number Code | L | N Number of Hole Rows | G | Number of Blocks | Travel Distance (mm) | Travel per Rotation (mm) | Minimum Graduation (mm) | Straightness (μm) | Parallelism (μm) | Load Capacity (kgf) | Body Weight (kg) | Part Number | |
|------------------|------|-----------------------|------|------------------|----------------------|--------------------------|-------------------------|-------------------|------------------|---------------------|------------------|-------------|-----|
| | | | | | | | | | | | | Code | L |
| EJR01 | 50 | 2 | 12.5 | | ±15 | | | | | | 0.12 | EJR01-L | 100 |
| | 70 | 3 | 10 | 1 | ±25 | | | 30 | 40 | 0.17 | EJR01-L150 | 150 | |
| | 100 | 4 | | | ±40 | 18 | 0.1 | | | 3.0 | 0.39 | | |
| | 150A | 6 | 12.5 | 2 | ±65 | | | 40 | | | 0.39 | | |
| | 200 | | | 1 | | | | 50 | 50 | | 0.45 | | |
| | 200A | 8 | | 2 | ±90 | | | | | | 0.51 | | |



| Code | L |
|-------|-----|
| EJR01 | 100 |
| EJR01 | 150 |

| Per | 1~4 | 5~ |
|-------|------|----------------------|
| Price | 100% | Additional quotation |

| Delivery | 10 |
|----------|----|
|----------|----|

Z-Axis

| Code | Type | Drive Direction | Material | Surface Treatment |
|-------|---------------------------|-----------------|----------------|-------------------|
| EJS01 | Rack & Pinion Long Stroke | Z-Axis | Aluminum Alloy | Black Anodize |

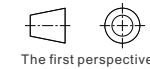
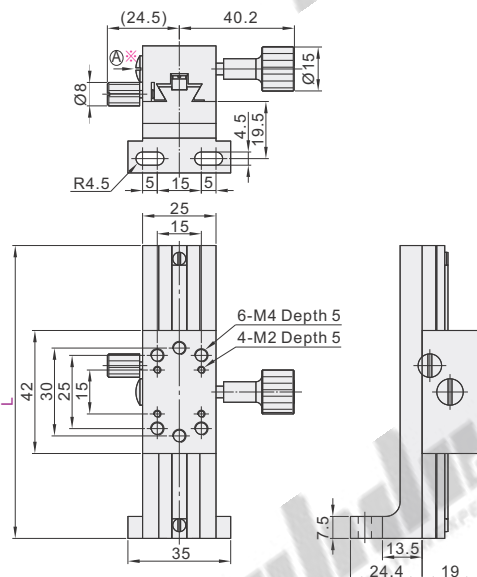

| Part Number Code | L | Travel Distance (mm) | Travel per Rotation (mm) | Minimum Graduation (mm) | Load Capacity (kgf) | Body Weight (kg) |
|------------------|-----|----------------------|--------------------------|-------------------------|---------------------|------------------|
| | | | | | | |
| | 70 | ±25 | | | | 0.16 |
| | 100 | ±40 | 18 | 0.1 | 1.5 | 0.24 |
| | 150 | ±65 | | | | |



| Code | L | Travel Distance (mm) |
|-------|-----|----------------------|
| EJS01 | 100 | ±40 |
| EJS01 | 150 | ±65 |

| Per | 1~9 | 10~ |
|-------|------|----------------------|
| Price | 100% | Additional quotation |

| Delivery | 10 |
|----------|----|
|----------|----|

※ By turning the preload adjustment screw (A) clockwise with a flathead screw driver, the stage slides slowly. By turning counterclockwise, the slides quickly and smoothly.

Dovetail Groove Guide Stages

X-Axis/Z-Axis

Standard, Long Stroke, Rack & Pinion Long Stroke

Positioning Stages

X-Axis

| Code | Type | Drive Direction | Material | Surface Treatment |
|-------|---------------------------|-----------------|----------------|-------------------|
| EJR11 | Rack & Pinion Long Stroke | X-Axis | Aluminum Alloy | Black Anodize |

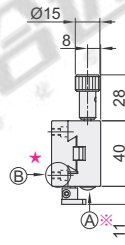
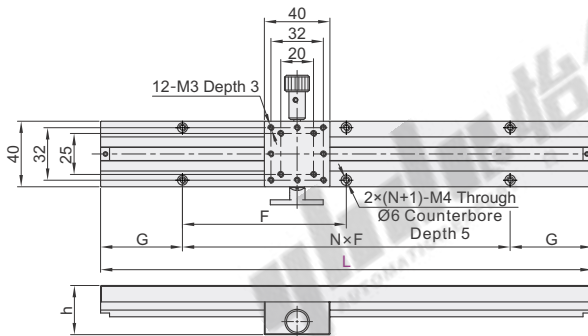

*(B) Mounting Hole Enlarged View

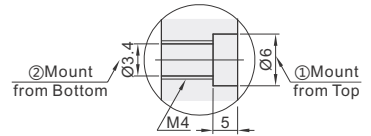

- ① Mount from Top: Use M3 Screws.
- ② Mount from Bottom: Use M4 Screws.

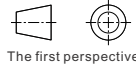

The first perspective

※ By turning the preload adjustment screw (A) clockwise with a flathead screw driver, the stage slides slowly. By turning counterclockwise, the slides quickly and smoothly.
 Ⓛ The product can choose two blocks, but the stroke should reduce the length of the corresponding blocks, and the total length of the slider cannot be greater than its own stroke.

| Part Number | Code | L | G | N×F Number of Hole Rows | h | Travel Distance (mm) | Travel per Rotation (mm) | Minimum Graduation (mm) | Parallelism (μm) | Load Capacity (kgf) | Body Weight (kg) |
|-------------|------|-------|------|----------------------------|----|----------------------|--------------------------|-------------------------|------------------|---------------------|------------------|
| EJR11 | 100 | 12.5 | 25 | 1×75 | 30 | ±30 | 18 | 0.1 | 50 | 5 | 0.25 |
| | 150 | 1×100 | | ±55 | | 0.33 | | | | | |
| | 200 | 2×75 | ±80 | 0.39 | | | | | | | |
| | 250 | 2×100 | ±105 | 0.46 | | | | | | | |
| | 300 | 2×100 | ±130 | 0.53 | | | | | | | |
| | 400 | 50 | 6×50 | ±180 | | 0.69 | | | | | |
| 500 | 8×50 | ±230 | 150 | 0.91 | | | | | | | |



| Part Number | Code | L | G |
|-------------|------|------|------|
| EJR11 | 100 | 12.5 | 12.5 |
| EJR11 | 150 | 25 | 25 |

EJR11—L100



Discount price

| Per | 1~9 | 10~ |
|-------|------|----------------------|
| Price | 100% | Additional quotation |



Z-Axis

| Code | Type | Drive Direction | Material | Surface Treatment |
|-------|---------------------------|-----------------|----------------|-------------------|
| EJS11 | Rack & Pinion Long Stroke | Z-Axis | Aluminum Alloy | Black Anodize |

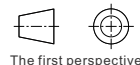
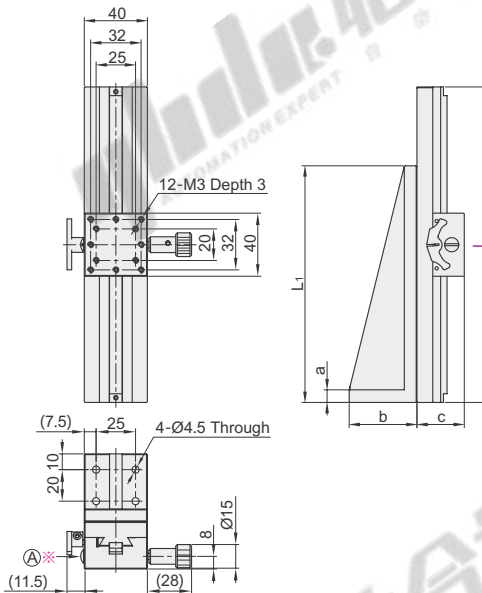

The first perspective

※ By turning the preload adjustment screw (A) clockwise with a flathead screw driver, the stage slides slowly. By turning counterclockwise, the slides quickly and smoothly.
 Ⓛ The product can choose two blocks, but the stroke should reduce the length of the corresponding blocks, and the total length of the slider cannot be greater than its own stroke.

| Part Number | Code | L | L1 | a | b | c | Travel Distance (mm) | Travel per Rotation (mm) | Minimum Graduation (mm) | Load Capacity (kgf) | Body Weight (kg) |
|-------------|------|------|----|----|------|------|----------------------|--------------------------|-------------------------|---------------------|------------------|
| EJS11 | 100 | 100 | 8 | 43 | 30 | 30 | ±30 | 18 | 0.1 | 2.5 | 0.46 |
| | 150 | ±55 | | | | | 0.54 | | | | |
| | 200 | ±80 | | | | | 0.6 | | | | |
| | 250 | ±105 | | | | | 0.67 | | | | |
| | 300 | ±130 | | | | | 0.74 | | | | |
| | 400 | ±180 | | | | | 1.05 | | | | |
| 500 | 400 | 10 | 45 | 35 | ±230 | 1.18 | | | | | |



| Part Number | Code | L | L1 |
|-------------|------|-----|-----|
| EJS11 | 100 | 100 | 100 |
| EJS11 | 150 | 150 | 150 |

EJS11—L100



Discount price

| Per | 1~9 | 10~ |
|-------|------|----------------------|
| Price | 100% | Additional quotation |



Lab Jack Stages

Horizontal Z-Axis

Positioning Stages



Self-made

| Code | Type | Drive Direction | Material | Surface Treatment |
|-------|-----------------------|-------------------|----------------|-------------------|
| ELE01 | Lab Jack Guide Stages | Horizontal Z-Axis | Aluminum Alloy | Black Anodize |

No.: 60

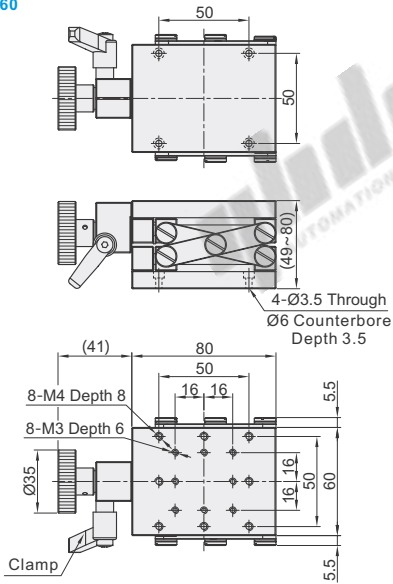

No.: 80

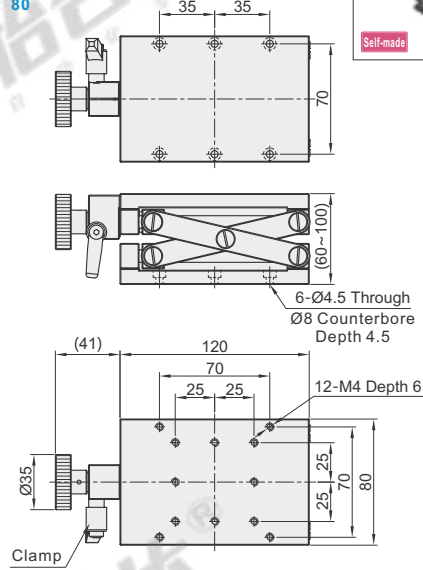

No.: 120

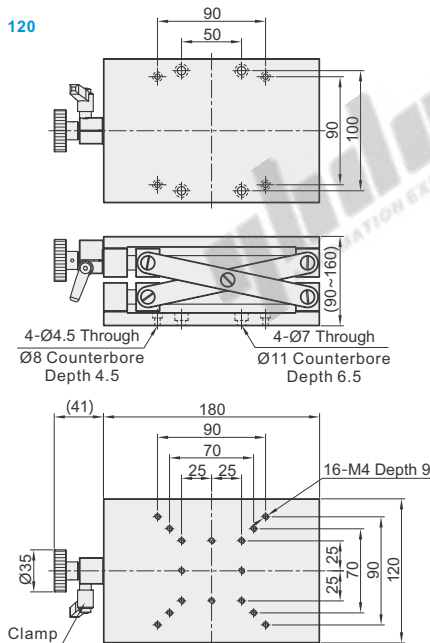

No.: 120A

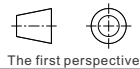
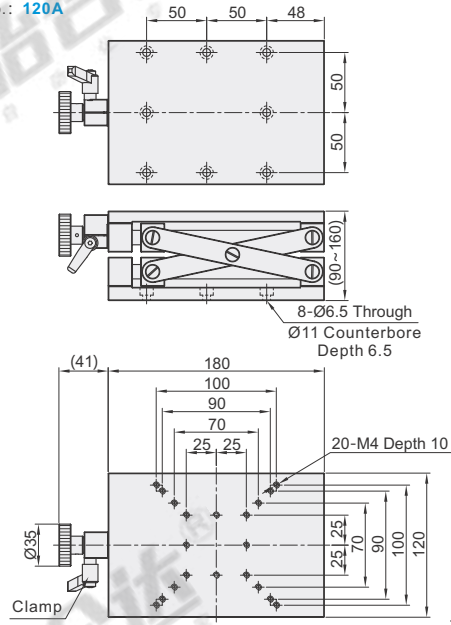

| Part Number | | Stage Surface | Travel Distance | Travel per Rotation | Parallelism | Load Capacity | Body Weight |
|-------------|------|---------------|-----------------|---------------------|-------------|---------------|-------------|
| Code | No. | (mm) | (mm) | (mm) | (μ m) | (kgf) | (kg) |
| ELE01 | 60 | 60×80 | 31 | 1.8 | 200 | 6 | 0.65 |
| | 80 | 80×120 | 40 | 2 | | 7 | 1.25 |
| | 120 | | | | | 10 | 3.5 |
| | 120A | 120×180 | 70 | 3 | | | |



Please order as shown

| Part Number | Stage Surface | |
|-------------|---------------|--------|
| Code | No. | (mm) |
| ELE01 | 60 | 60×80 |
| | 80 | 80×120 |

ELE01-60



| Discount price | |
|----------------|----------------------|
| Per | Additional quotation |
| 1~9 | 10~ |
| Price 100% | |



| Delivery |
|----------|
| 13 |

| Code | Type | Material | Surface Treatment |
|-------|----------------------|-----------------|-------------------|
| ELF31 | Cross Roller Bearing | Stainless Steel | — |
| ELF33 | | Aluminum Alloy | Black Anodize |



ELF31-60

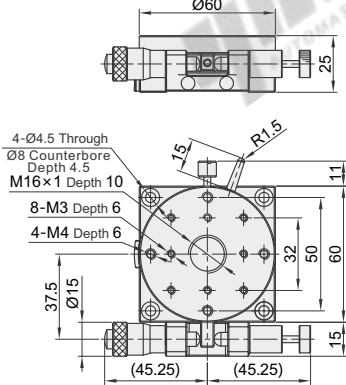

ELF31-85

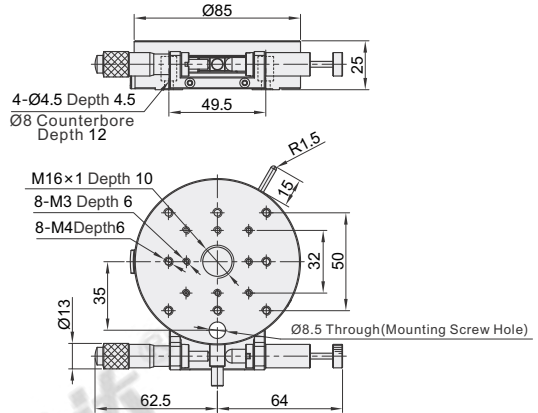

ELF33-100

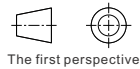
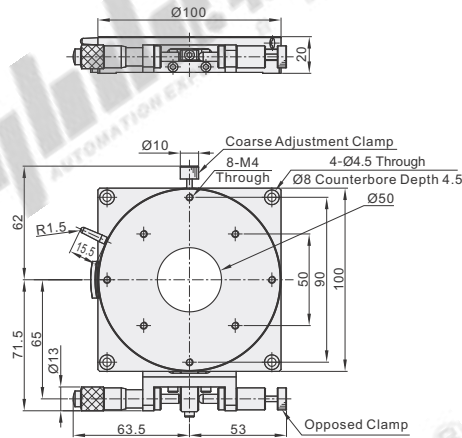

| Part Number Code | Stage Surface No. | Travel Distance (mm) | Minimum Graduation | | Load Capacity(N) Horizontal | Eccentricity (mm) | Body Weight (kg) | Accessories(4pcs) Hex Socket Head Cap Screw (Stainless Steel) |
|---------------------|----------------------|---------------------------|--------------------|-------------------------|--------------------------------|----------------------|---------------------|---|
| | | | Vernier | Micrometer | | | | |
| ELF31 | 60 | Coarse Adjustment 360° | 0.2° | ≈55(°/Scale Graduation) | 49 | 0.05 | 0.58 | TAC21-M4-L8 |
| | 85 | | | ≈42(°/Scale Graduation) | | | | |
| ELF33 | 100 | Fine Adjustment ±5° | 0.1° | ≈32(°/Scale Graduation) | 58.8 | | 0.45 | TAC21-M4-L6 |



| Part Number | Stage Surface |
|-------------|---------------|
| Code No. | (mm) |
| ELF31 | 60 |
| | 85 |
| ELF31-60 | |



| Discount price | |
|----------------|---------------------------|
| Per | 1~9 |
| Price | 100% Additional quotation |



| Delivery |
|----------|
| 13 |

Goniometer Stages

X-Axis Dovetail Slide

Positioning Stages

| Code | Type | Drive Direction | Material | Surface Treatment |
|-------|----------------|-----------------|--------------|--------------------|
| ELJ01 | Dovetail Slide | X-Axis | Copper Alloy | Black Fluoro Resin |

ELJ01-40-25

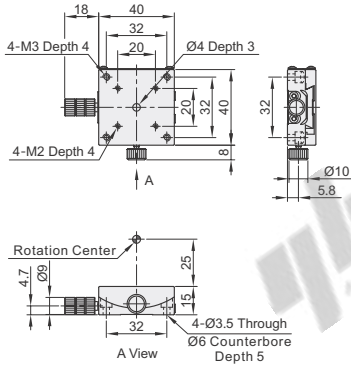

ELJ01-40-40

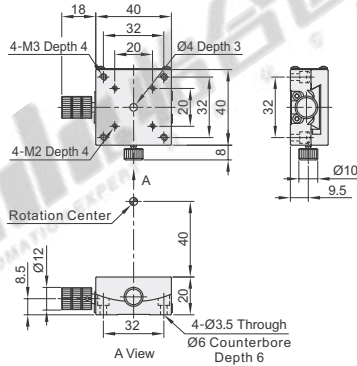

Self-made



ELJ01-40-60

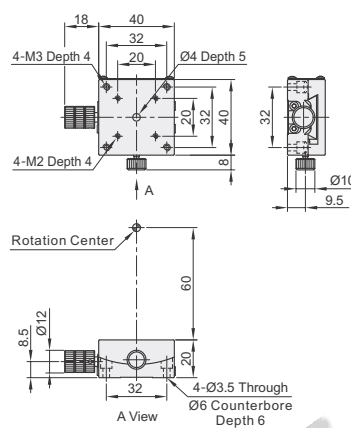

ELJ01-50-50

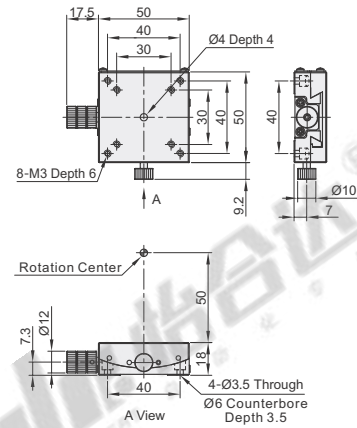

ELJ01-50-68

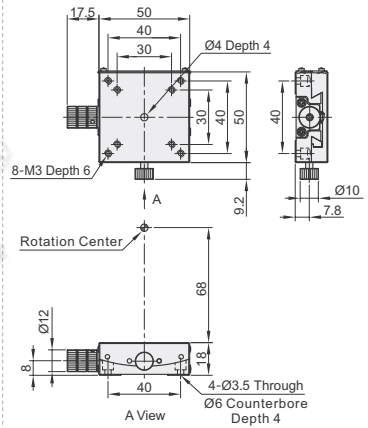

ELJ01-60-35

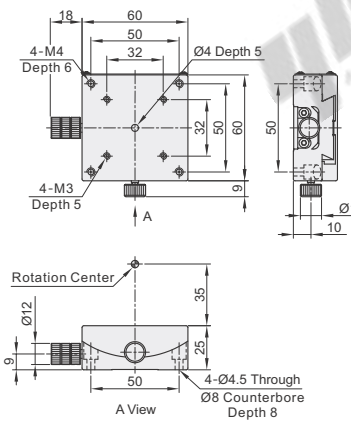

ELJ01-60-60

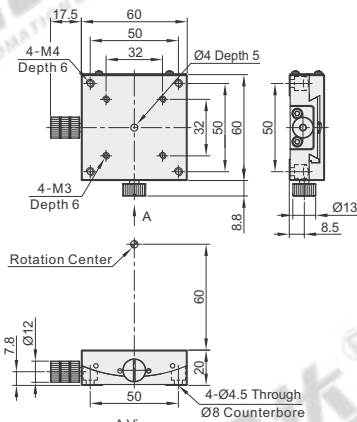

ELJ01-60-80

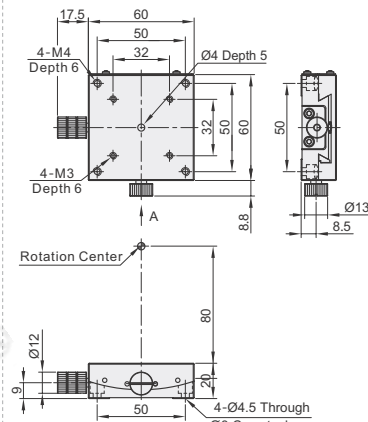

| Code | Part Number | | Stage Surface (mm) | Travel Distance | Travel per Rotation | Minimum Graduation | Body Weight (kg) | Load Capacity (kgf) |
|-------|-------------|--------------------|--------------------|-----------------|---------------------|--------------------|------------------|---------------------|
| | No. | Center Height (mm) | | | | | | |
| ELJ01 | 40 | 25 | 40×40 | ±20° | 2.2° | 0.1° | 0.18 | 3 |
| | | 40 | | | 1.89° | | 0.24 | |
| | 50 | 60 | 50×50 | ±10° | 1.33° | 0.1° | 0.45 | 5 |
| | | 50 | | | 1.58° | | | |
| | 60 | 68 | 60×60 | ±20° | 1.21° | 0.1° | 0.69 | 5 |
| | | 35 | | | 2.0° | | | |
| | | 80 | | 1.02° | | 0.8 | | |



| Part Number | | | Stage Surface (mm) |
|-------------|-----|---------------|--------------------|
| Code | No. | Center Height | |
| ELJ01 | 40 | 25 | 40×40 |
| ELJ01 | 40 | 40 | 40×40 |



| Discount price | |
|----------------|---------------------------|
| Per | 1~9 10~ |
| Price | 100% Additional quotation |



| Delivery | |
|----------|----|
| | 13 |

| Code | Type | Drive Direction | Material | Surface Treatment |
|-------|----------------|-----------------|--------------|--------------------|
| ELK01 | Dovetail Slide | XY-Axis | Copper Alloy | Black Fluoro Resin |



Self-made

ELK01-40-25

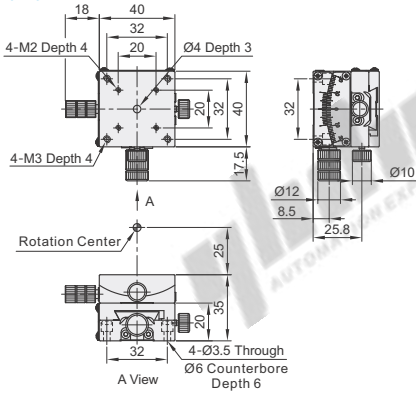

ELK01-60-35

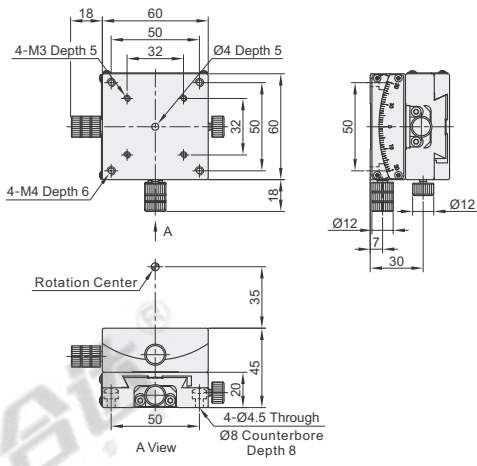

ELK01-40-40

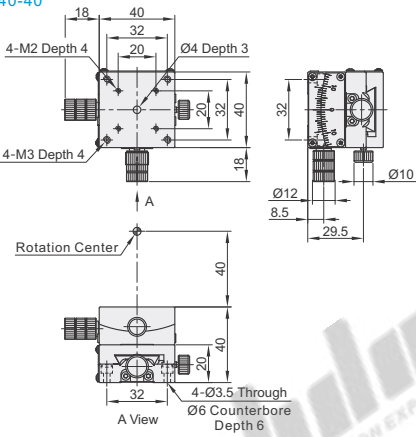

ELK01-60-60

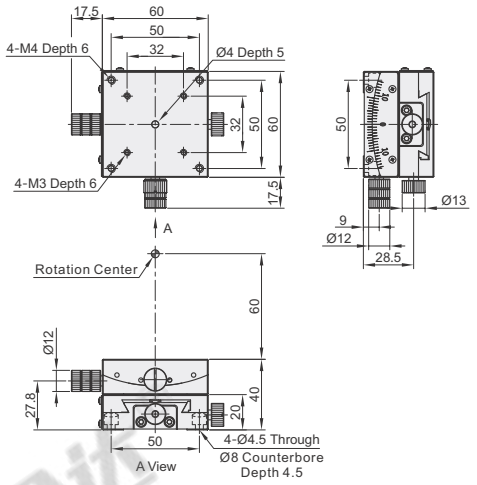

ELK01-50-50

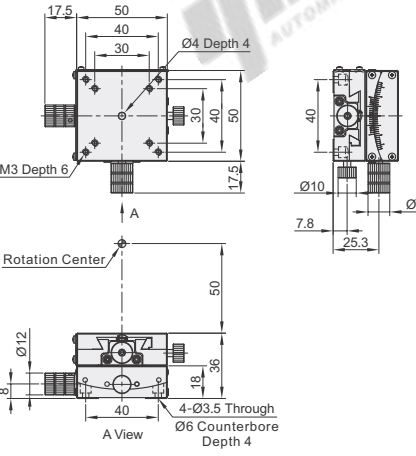

| Code | Part Number | | Stage Surface (mm) | Travel Distance | Minimum Graduation | Travel per Rotation | Load Capacity (N) | Body Weight (kg) |
|-------|-------------|--------------------|---------------------|---------------------|-----------------------|------------------------|-------------------|------------------|
| | No. | Center Height (mm) | | | | | | |
| ELK01 | 40 | 25 | 40×40 | Top±25°, Bottom±15° | 0.1° | Top±2.0°, Bottom±2.0° | 27.4 | 0.48 |
| | 40 | 40 | | | | | | |
| | 50 | 50 | 50×50 | Top±10°, Bottom±10° | 0.1° | Top±1.9°, Bottom±1.35° | 26.4 | 0.49 |
| | 50 | 35 | | | | | | |
| 60 | 35 | 60×60 | Top±25°, Bottom±20° | 0.1° | Top±2.0°, Bottom±1.3° | 51.9 | 1.24 | |
| 60 | 60 | | | | | | | |
| | | | | | | | | |
| | | | | | | | | |
| | | | | | | | | |
| | | | | | | | | |

| Part Number | | | Stage Surface (mm) |
|-------------|-----|---------------|--------------------|
| Code | No. | Center Height | |
| ELK01 | 40 | 25 | 40×40 |
| ELK01 | 40 | 40 | |
| ELK01-40-40 | | | |

Discount price

| | | |
|-------|------|----------------------|
| Per | 1~9 | 10~ |
| Price | 100% | Additional quotation |

Delivery

13



Goniometer Stages

X-Axis, Micrometer Head Cross Roller



Self-made

| Code | Type | Drive Direction | Material | Surface Treatment |
|-------|-----------------|-----------------|----------------|-------------------|
| ELK51 | Micrometer Head | X-Axis | Aluminum Alloy | Black Anodize |

ELK51-40-40

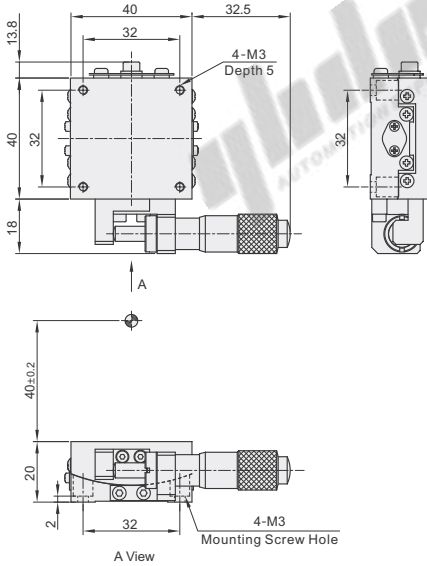

ELK51-40-60

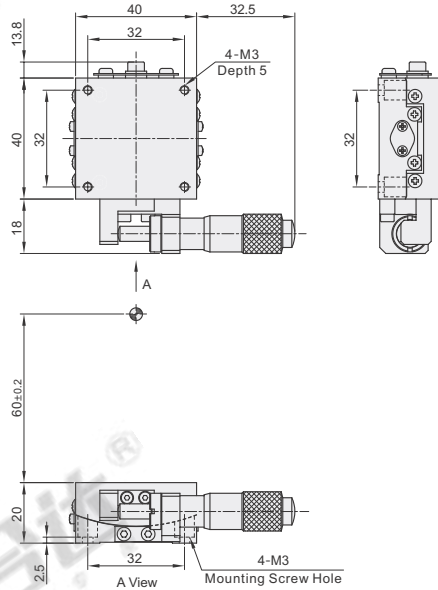

ELK51-60-50

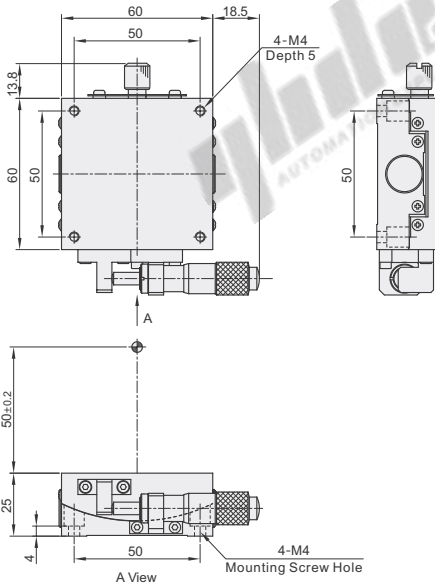

ELK51-60-75

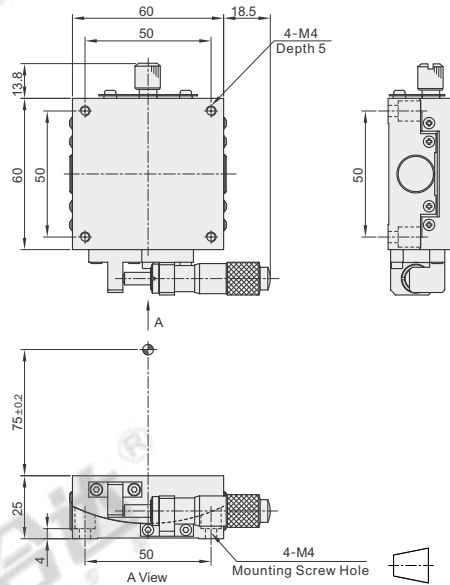

The first perspective

| Part Number | | Center Height (mm) | Stage Surface (mm) | Travel Distance | Min. Reading ("/division) | Load Capacity (kgf) | Body Weight (kg) |
|-------------|-----|--------------------|--------------------|-----------------|---------------------------|---------------------|------------------|
| Code | No. | | | | | | |
| ELK51 | 40 | 40 | 40×40 | ±7° | ≈45 | 3 | 0.13 |
| | 60 | 60 | | | ≈35 | | |
| | 60 | 50 | 60×60 | ±6° | ≈35 | 5 | 0.29 |
| | | 75 | | | ≈25 | | |



| Part Number | | | Stage Surface |
|-------------|-----|---------------|---------------|
| Code | No. | Center Height | (mm) |
| ELK51 | 40 | 40 | 40×40 |
| | 60 | 60 | |
| | 50 | 50 | |
| | 75 | 75 | |

ELK51-40-60



| Discount price | | |
|----------------|------|----------------------|
| Per | 1~9 | 10~ |
| Price | 100% | Additional quotation |



| Delivery | |
|----------|-----|
| Per | 10~ |
| Price | 10 |

| Code | Type | Drive Direction | Material | Surface Treatment |
|-------|-----------------|-----------------|----------------|-------------------|
| ELK56 | Micrometer Head | XY-Axis | Aluminum Alloy | Black Anodize |



No.: 40

No.: 60

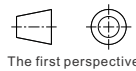
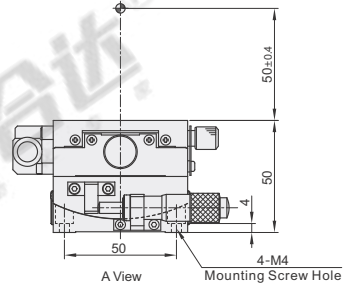
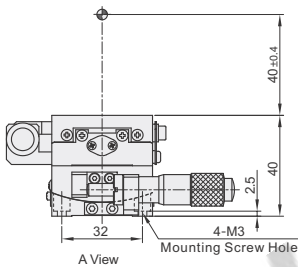
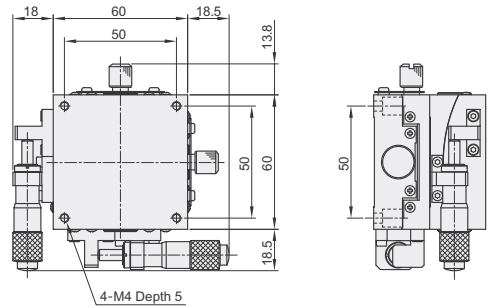
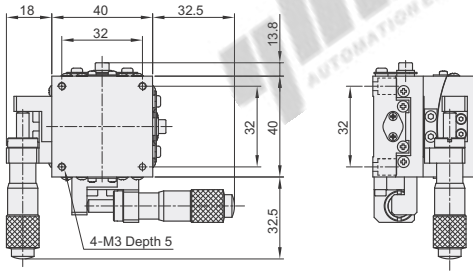

| Part Number | | Center Height (mm) | Stage Surface (mm) | Travel Distance | Min. Reading ("/division) | Load Capacity (kgf) | Body Weight (kg) |
|-------------|-----|--------------------|--------------------|-------------------|---------------------------|---------------------|------------------|
| Code | No. | | | | | | |
| ELK56 | 40 | 40 | 40×40 | Top±7°, Bottom±6° | Top≈45, Bottom≈35 | 3 | 0.26 |
| | 60 | 50 | 60×60 | Top±6°, Bottom±4° | Top≈35, Bottom≈25 | 5 | 0.58 |



| Part Number | | Center Height | Stage Surface |
|-------------|-----|---------------|---------------|
| Code | No. | | |
| ELK56 | 40 | 40 | 40×40 |
| ELK56 | 60 | 50 | 60×60 |

ELK56—40



| Discount price | |
|----------------|----------------------|
| Per | Price |
| 1~9 | 100% |
| 10~ | Additional quotation |



| Delivery | |
|----------|----------------------|
| Per | Price |
| 1~9 | 10 |
| 10~ | Additional quotation |

X-Axis, Standard ▶ Simplified Adjustments Feed Screw

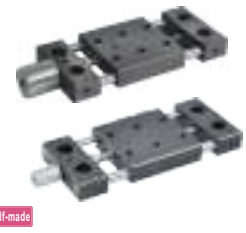

Sell-made

| Code | Type | | Main Body | | Shaft | Handle | Feed Screw | Accessories |
|-------|----------|-----------------|-----------|-------------------|----------|----------|------------|---------------------------|
| | | | Material | Surface Treatment | Material | Material | Material | |
| HHB01 | Standard | Standard Handle | A6063 | Black Anodize | SUS304 | SUS303 | SUS304 | Hex Socket Head Cap Screw |
| HHB21 | Type | Large Handle | | | | | | |

☑ Accessories

| No. | Accessories | | Qty. | Material |
|-----|-------------------------------|--------------|-------|----------|
| 20 | Hex Socket Low Head Cap Screw | TAF01-M3-L12 | | SCM435 |
| 25 | | TAC21-M3-L12 | | |
| 40 | | | | |
| 40A | Hex Socket Head Cap Screw | TAC21-M4-L12 | 4 pcs | SUS304 |
| 60 | | | | |
| 60A | | | | |
| 60B | | | | |

No.: 20

☑ Handle

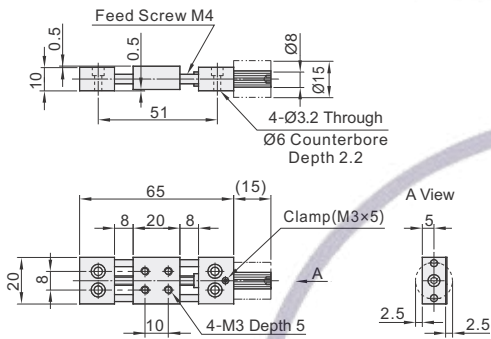

Standard Handle

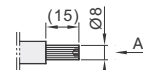

A View



Large Handle

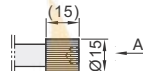

A View



No.: 25

No.: 40

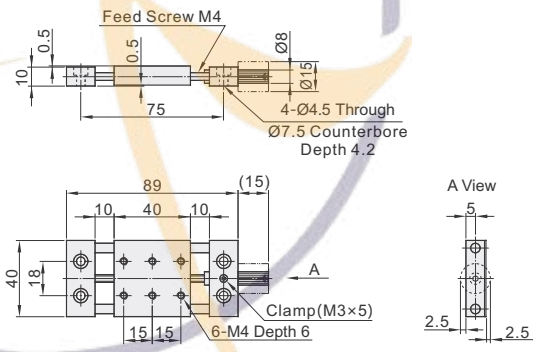
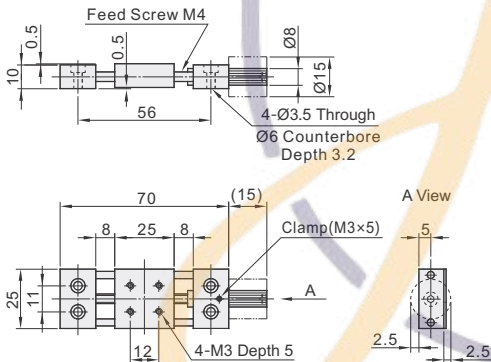

No.: 40A

No.: 60

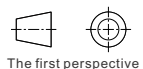
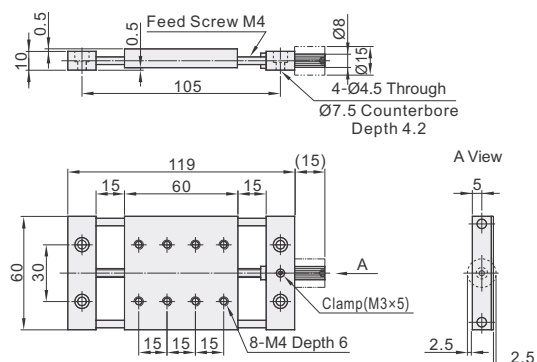
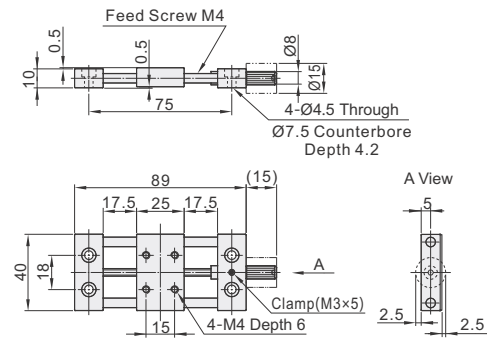

The first perspective

Positioning Stages
E8

Simplified Adjustments

X-Axis, Standard Feed Screw

Positioning Stages

No.: 60A

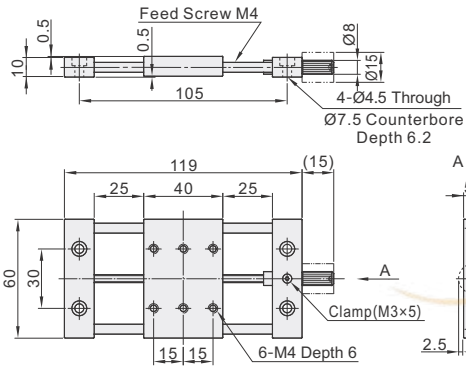

No.: 60B

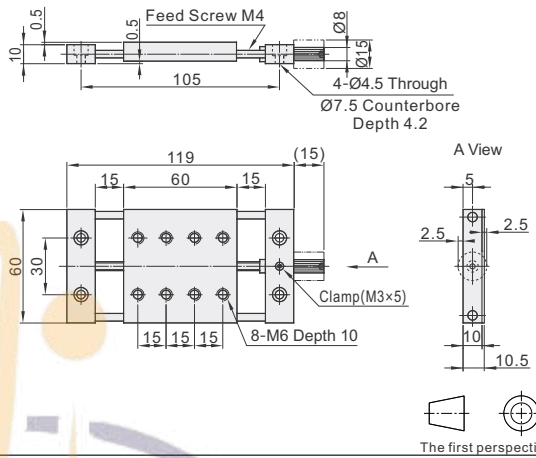

- Accuracy Standards
- Not recommended for precise positioning.

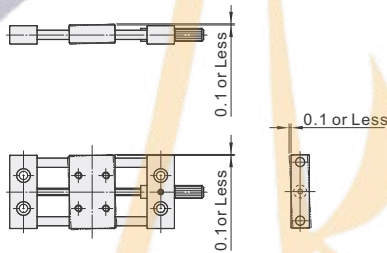

| Part Number | | Stage Surface (mm) | Travel Distance (mm) | Load Capacity(N) | | Weight (g) |
|--------------------------|-----|--------------------|----------------------|------------------|----------|------------|
| Code | No. | | | Horizontal | Vertical | |
| Standard Handle HHB01 | 20 | 20×20 | ±7 | 19.6 | 9.8 | 39 |
| | 25 | 25×25 | | | | 49 |
| | 40 | 40×40 | ±9 | | | 104 |
| Large Handle HHB21 | 40A | 40×25 | ±17 | | | 91 |
| | 60 | 60×60 | ±13 | 39.2 | 19.6 | 176 |
| | 60A | 60×40 | ±23 | | | 147 |
| | 60B | 60×60 | ±13 | | | 176 |

Travel per rotation 0.7 mm.



Please order as shown

| Part Number | | Stage Surface (mm) |
|-------------|-----|--------------------|
| Code | No. | |
| HHB01 | 20 | 20×20 |
| | 25 | 25×25 |

HHB01-20



| Discount price | | |
|----------------|------|----------------------|
| Per | 1~9 | 10~ |
| Price | 100% | Additional quotation |



| Delivery |
|----------|
| 10 |

Simplified Adjustments

X-Axis, Heavy Load Feed Screw

Positioning Stages
E8

| Code | Type | Material | Surface Treatment |
|-------|------------|----------|-------------------|
| HHQ01 | Heavy Load | A6063 | Clear Anodize |

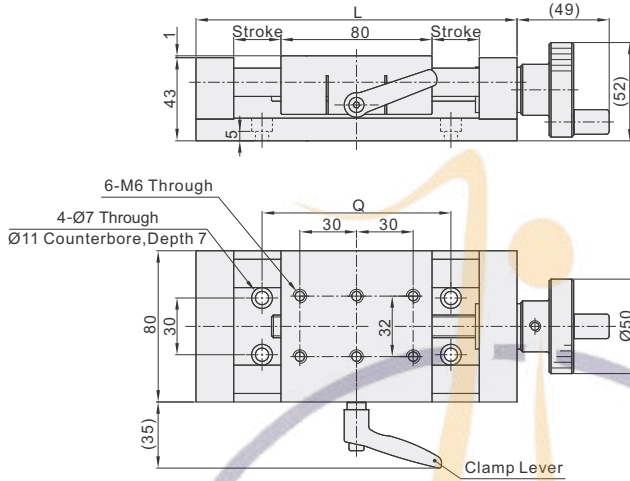
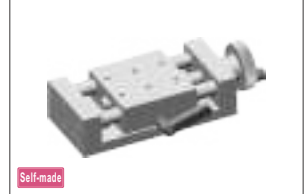

The first perspective

| Part Number | | Stage Surface (mm) | Travel Distance (mm) | Lead (mm) | L | Q | Load Capacity (N) | Weight (kg) | Accessories(4pcs) Hex Socket Head Cap Screw (Stainless Steel) | Clamp Lever (1pc.) |
|-------------|-----|--------------------|----------------------|-----------|-----|-----|-------------------|-------------|--|--------------------|
| Code | No. | | | | | | | | | |
| HHQ01 | 50 | 80x80 | 25 | 2 | 170 | 100 | 196 | 1.72 | TAC21-M6-L15 | HAF74-M6-L20-G |
| | 100 | | 50 | | 220 | 150 | | | | |
| | 150 | | 75 | | 270 | 200 | | | | |



| Part Number | | Stage Surface (mm) |
|-------------|-----|--------------------|
| Code | No. | |
| HHQ01 | 100 | 80x80 |
| | 150 | |

HHQ01-100

Optional Processing

| Part Number | | Optional Processing Code |
|-------------|-----|--------------------------|
| Code | No. | |
| HHQ01 | 100 | QR |
| | 150 | |

HHQ01-100-QR



| Code | QR |
|--|----|
| Position of Handle (Right and Left Side Reversed) | |
| Ordering Code | QR |

Spec.

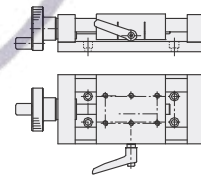

Discount price

| Per Price | 1~9 | 10~ | Additional Quotation |
|-----------|------|-----|----------------------|
| | 100% | | |



Delivery
10

| Code | Type | Drive direction | Material | Surface Treatment |
|-------|-------------------------|-----------------|----------------|-------------------|
| HHQ31 | Heavy Load | X-Axis | Aluminum Alloy | Clear Anodize |
| HHQ36 | With Position Indicator | | | |

Heavy Load
HHQ31

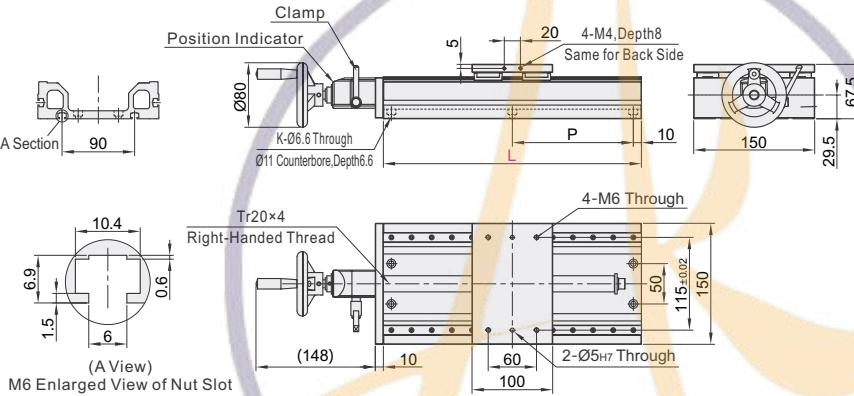
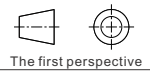
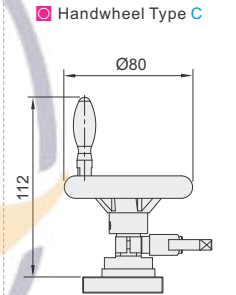
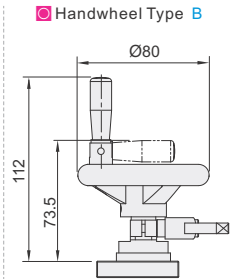
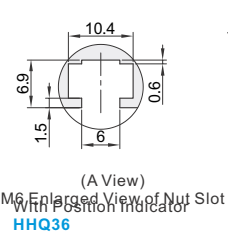
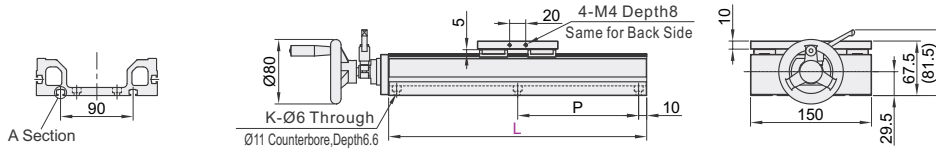

| Part Number Code | L | Handwheel Type | Effective Stroke (mm) | Lead Screw Lead (mm) | Load Capacity (N) | Base Mounting Hole | | Parallelism (mm) | Backlash (mm) | Weight (kg) | | | | |
|---------------------|-------------------------------|-----------------------------------|-----------------------|----------------------|-------------------|--------------------|---------------------|------------------|---------------|-------------|-----|-----|---|-----|
| | | | | | | P (Pitch) | K (Number of Holes) | | | | | | | |
| HHQ31 HHQ36 | 170 | Not Specified (Plastic Handwheel) | 53 | 4 | 1470 | 150 | 4 | 0.15 | 0.3 | 4.2 | | | | |
| | 220 | | 103 | | | 200 | | | | | | | | |
| | 320 | | 203 | | | 150 | | | | | | | | |
| | B (Folding Plastic Handwheel) | 370 | 253 | | | 6 | 0.15 | | | | 0.3 | 6.2 | | |
| | | 420 | 303 | | | | | | | | | | 8 | 7.2 |
| | | 470 | 353 | | | | | | | | | | | |



| Code | QA | QU | QD | QL | QR |
|-------|------------------------------|------------------|------------------|------------------|------------------|
| | Enhanced Side Locking | 手轮转向向上 | 手轮转向向下 | 手轮转向向左 | 手轮转向向右 |
| | Ordering Code QA | Ordering Code QU | Ordering Code QD | Ordering Code QL | Ordering Code QR |
| Spec. | | | | | |



| Part Number | Handwheel Type |
|-------------|-----------------------------------|
| Code L | |
| HHQ31 170 | Not Specified (Plastic Handwheel) |
| HHQ31 220 | B (Folding Plastic Handwheel) |

HHQ31-L170

| Part Number | Handwheel Type | Optional Processing Code |
|-------------|-----------------------------------|--------------------------|
| Code L | | |
| HHQ31 170 | Not Specified (Plastic Handwheel) | QA QU... |
| HHQ31 220 | B (Folding Plastic Handwheel) | |

HHQ31-L170-QA

Simplified Adjustments

- ◀ Z-Axis, Heavy Load
- ◀ Z-Axis, With Position Indicator Lead Screw

| Code | Type | Drive direction | Material | Surface Treatment |
|-------|-------------------------|-----------------|----------------|-------------------|
| HHQ41 | Heavy Load | Z-Axis | Aluminum Alloy | Clear Anodize |
| HHQ46 | With Position Indicator | | | |

Heavy Load
HHQ41

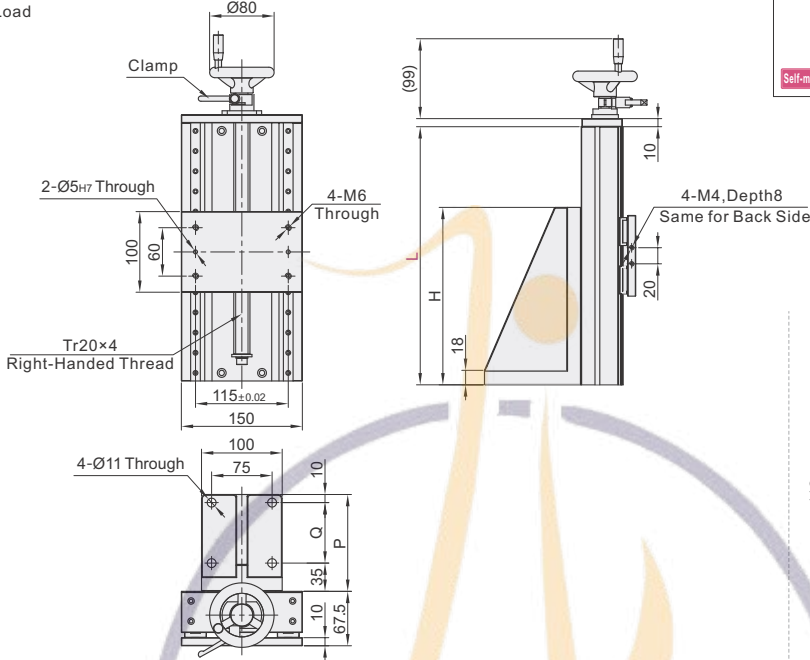

Self-made

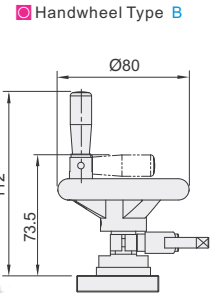

With Position Indicator
HHQ46

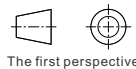
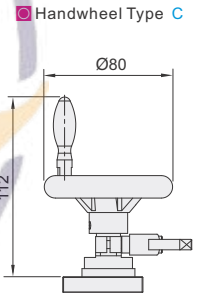
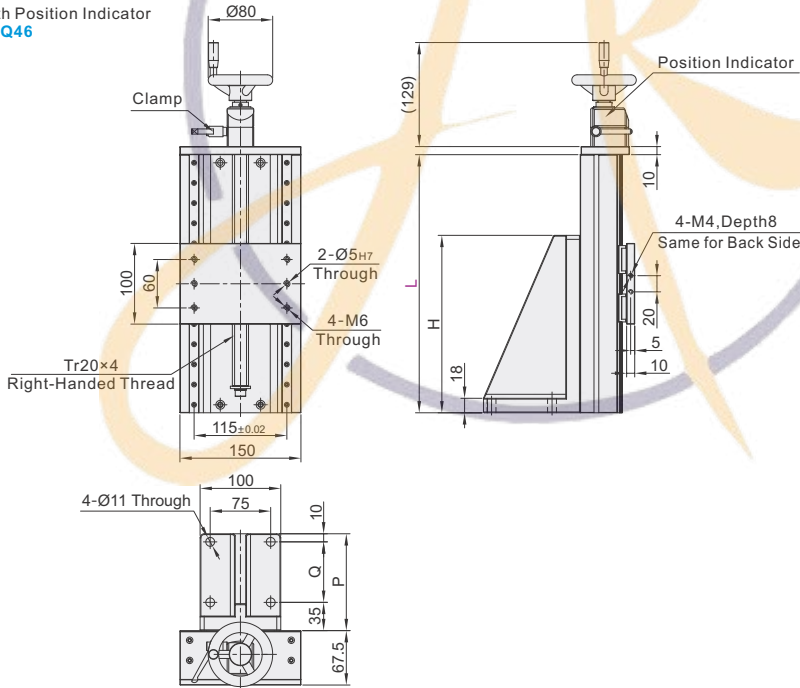

| Part Number | | Handwheel Type | Effective Stroke (mm) | Load Capacity (N) | H | Q | P | Parallelism (mm) | Backlash (mm) | Weight (kg) |
|-------------|-----|-----------------------------------|-----------------------|-------------------|-----|-----|-----|------------------|---------------|-------------|
| Code | L | | | | | | | | | |
| HHQ41 | 170 | Not Specified (Plastic Handwheel) | 62 | 294 | 220 | 75 | 120 | 0.15 | 0.3 | 6.8 |
| | 220 | | 112 | | | | | | | 7.5 |
| | 320 | B (Folding Plastic Handwheel) | 212 | | | | | | | 8.6 |
| | 370 | C (Five Spoked Handwheel) | 262 | | | | | | | 9.2 |
| HHQ46 | 420 | C (Five Spoked Handwheel) | 312 | 350 | 105 | 150 | | | | 11.0 |
| | 470 | | 362 | | | | | | | 11.5 |

Please order as shown

| Part Number | | Handwheel Type |
|-------------|-----|-----------------------------------|
| Code | L | |
| HHQ41 | 170 | Not Specified (Plastic Handwheel) |
| | 220 | |
| HHQ41—L170 | | |

| Part Number | | Handwheel Type | Optional Processing Code |
|---------------|-----|-----------------------------------|--------------------------|
| Code | L | | |
| HHQ41 | 170 | Not Specified (Plastic Handwheel) | QA QU... |
| | 220 | | |
| HHQ41—L170—QA | | | |

Optional processing see HHQ31/HHQ36.

| Code | Type | Block | | |
|-------|-------------------|--------|----------------|-------------------|
| | | Post | Material | Surface Treatment |
| HHT81 | Scaled Post Units | SUS304 | Aluminum Alloy | Clear Anodize |



Self-made

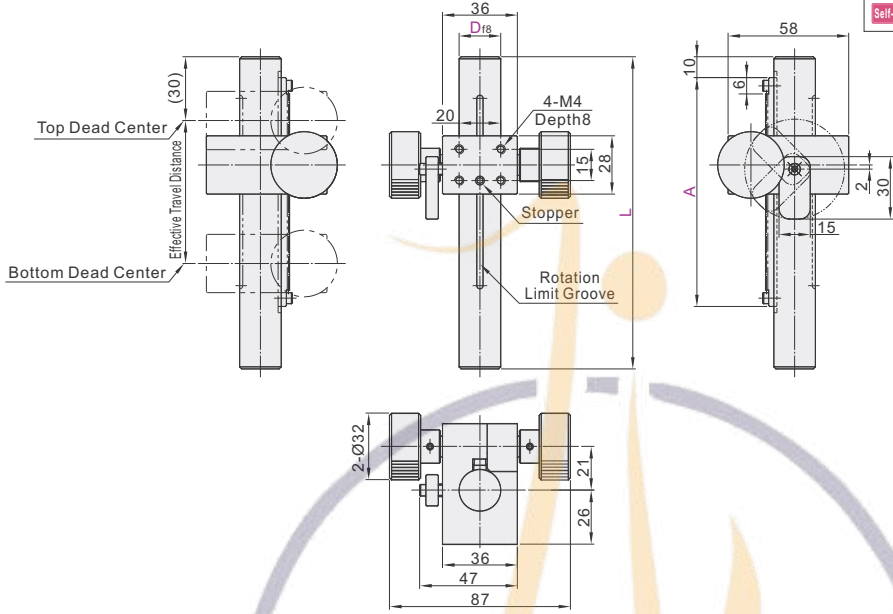

The scale unit is 0.1mm.

| Part Number | | D | L | A | Travel Distance (mm) | Load Capacity (N) | Weight (kg) |
|-------------|----|------------------|-----|-----|----------------------|-------------------|-------------|
| Code | D | Tolerance | | | | | |
| HHT81 | 20 | -0.020 -0.053 | 150 | 110 | 70 | 25 | 0.6 |
| | | | 200 | 160 | 120 | | 0.7 |
| | | | 250 | 210 | 170 | | 0.9 |
| | | | 300 | | | | 1 |
| | | | 480 | | | | 1.36 |



| Part Number | D | D | L | A |
|-------------|----|------------------|------------|------------|
| Code | D | Tolerance | | |
| HHT81 | 20 | -0.020 -0.053 | 250 300 | 160 210 |

HHT81 - D20 - L250 - A160



| Discount price | | |
|----------------|------|----------------------|
| Per | 1~9 | 10~ |
| Price | 100% | Additional quotation |

| Delivery | |
|----------|--|
| 10 | |

Simplified Adjustments

X-Axis, Standard Push Screw

Positioning Stages



Self-made

| Code | Type | | Main Body | | Shaft | | Spring | Push Screw | | Accessories |
|-------|----------|-----------------|-----------|-------------------|----------|----------|----------|------------|----------------------------|---------------------------|
| | | | Material | Surface Treatment | Material | Hardness | Material | Material | Surface Treatment | |
| HHJ01 | Standard | Standard Handle | A6063 | Black Anodize | SUS304 | 56HRC~ | SUS631 | S45C | Electroless Nickel Plating | Hex Socket Head Cap Screw |

Accessories

| No. | Accessories(Screws) | Qty. | Material |
|-----|-------------------------------|-------|----------|
| 20 | Hex Socket Head Cap Screw | 2 pcs | SUS304 |
| 25 | Hex Socket Low Head Cap Screw | 4 pcs | SCM435 |
| 40 | Hex Socket Low Head Cap Screw | 4 pcs | SCM435 |
| 60 | Hex Socket Low Head Cap Screw | 4 pcs | SCM435 |

No.: 20

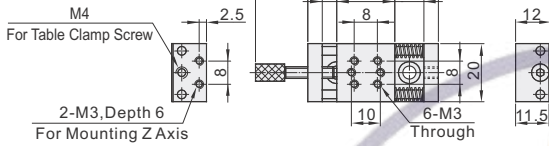
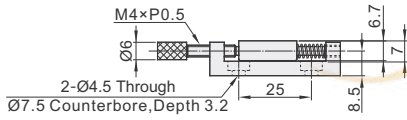

No.: 25

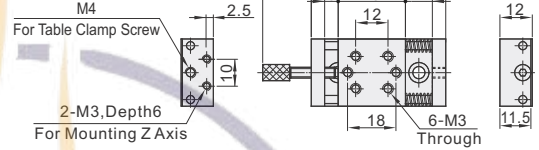
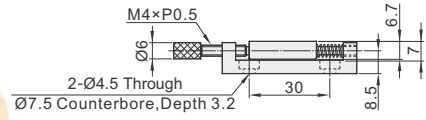

No.: 40

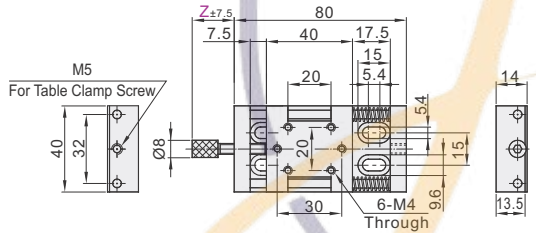
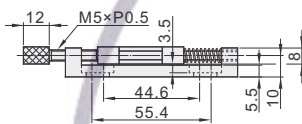

No.: 60

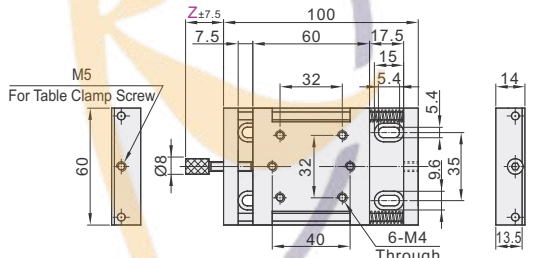
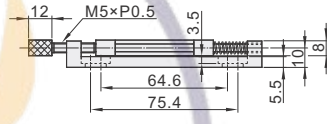

The first perspective

Accuracy Standards

Not recommended for precision positioning.

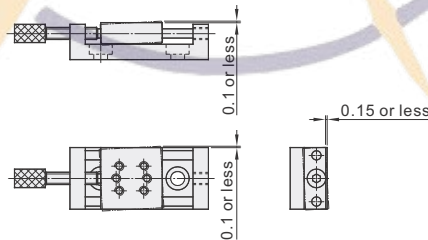

| Part Number | | Z | Stage Surface (mm) | Travel Distance (mm) | Load Capacity(N) | | Weight (g) |
|-------------|-----|------------|--------------------|----------------------|------------------|----------|------------|
| Code | No. | | | | Horizontal | Vertical | |
| HHJ01 | 20 | 18 28 38 | 20×20 | ±5 | 9.8 | 2 | 38 |
| | 25 | 19.5 30 40 | 25×25 | ±5 | 9.8 | 2 | 55 |
| | 40 | 19.5 30 40 | 40×40 | ±7.5 | 14.7 | 8 | 104 |
| | 60 | 19.5 40 60 | 60×60 | ±7.5 | 14.7 | 8 | 193 |

Travel Distance Per Handle Rotation: 0.5 mm.



| Part Number | | Z |
|-------------|-----|------------|
| Code | No. | |
| HHJ01 | 20 | 18 28 38 |
| | 25 | 19.5 30 40 |

HHJ01 - 20 - Z28



| Discount price | |
|----------------|---------------------------|
| Per | 1~9 10~ |
| Price | 100% Additional quotation |



Economy Cross Roller Guide Stages

X-Axis Micrometer Head



Self-made

| Code | Type | Drive Direction | Material | Surface Treatment |
|---------|-----------------|-----------------|----------------|-------------------|
| E-EIC01 | Micrometer Head | X-Axis | Aluminum Alloy | Black Anodize |

No.: 40

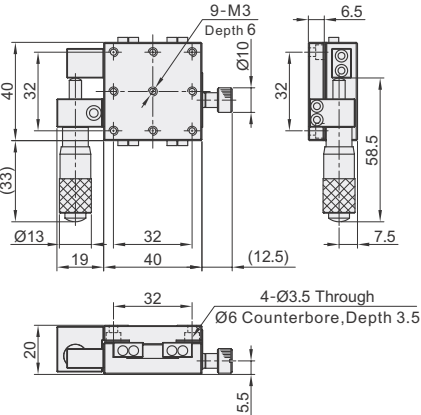

No.: 60

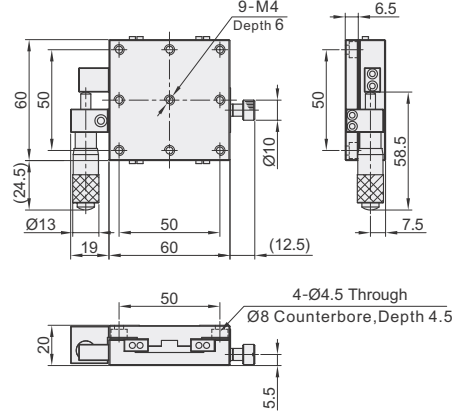

No.: 80

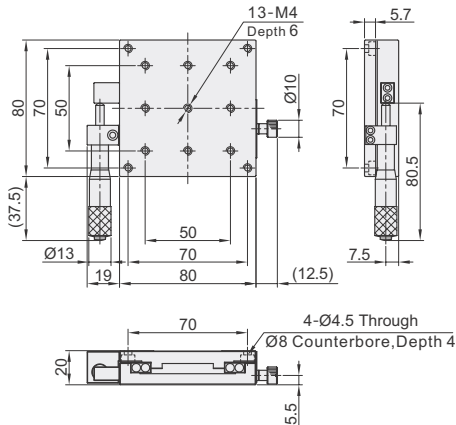

No.: 125

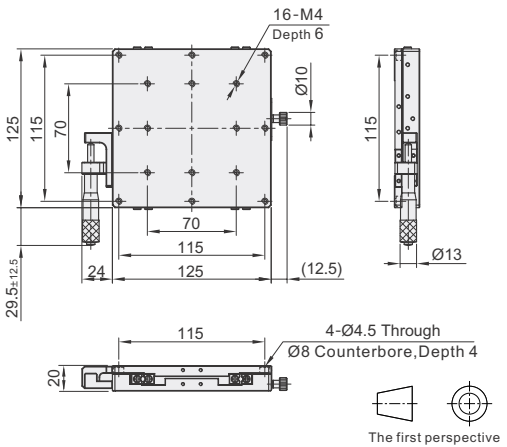

| Part Number | | Stage Surface (mm) | Drive Position | Travel Distance (mm) | Minimum Graduation (µm) | Parallelism (µm) | Load Capacity (kgf) | Body Weight (kg) |
|-------------|-----|--------------------|----------------|----------------------|-------------------------|------------------|---------------------|------------------|
| E-EIC01 | 40 | 40×40 | Side Face | ±6.5 | 10 | 40 | 2 | 0.14 |
| | 60 | 60×60 | | | | | 5 | 0.25 |
| | 80 | 80×80 | Left Side | ±12.5 | 50 | 10 | 0.5 | |
| | 125 | 125×125 | | | | 20 | 1.7 | |

| Code | QR | QU | QV | QC | CZ | T | MN |
|---------------------|---|--|---|---|--|--|--|
| Optional Processing | Micrometer changed to left and right (reverse) position [Ordering Code] QR | Micrometer changed to up and down (reverse) position [Ordering Code] QU | Micrometer changed to up, down, left and right (reverse) position [Ordering Code] QV | Micrometer changed to center position [Ordering Code] QC | Micrometer changed to up and down (reverse) position [Ordering Code] CZ | Opposite Clamp Bolt Enhance locking power [Ordering Code] T | No Micrometer Head [Ordering Code] MN |
| Spec. | | ① The micrometer knob is installed on the upper part of the stage. | ① The micrometer knob is installed on the upper part of the stage. | | ① The micrometer knob is installed on the upper part of the stage. | Opposite Clamp Bolt | |

| Part Number | | Stage Surface (mm) |
|-------------|-----|--------------------|
| Code | No. | |
| E-EIC01 | 40 | 40×40 |
| E-EIC01 | 60 | 60×60 |

| Optional Processing | | |
|---------------------|---------------------|------|
| Part Number | Optional Processing | Code |
| E-EIC01 | 40 | QR |
| E-EIC01 | 60 | QU |
| E-EIC01 | 40 | QV |
| E-EIC01 | 60 | QC |



Self-made

| Code | Type | Drive Direction | Material | Surface Treatment |
|---------|-----------------|-----------------|----------------|-------------------|
| E-EIC31 | Micrometer Head | Standard | Aluminum Alloy | Black Anodize |

No.: 40

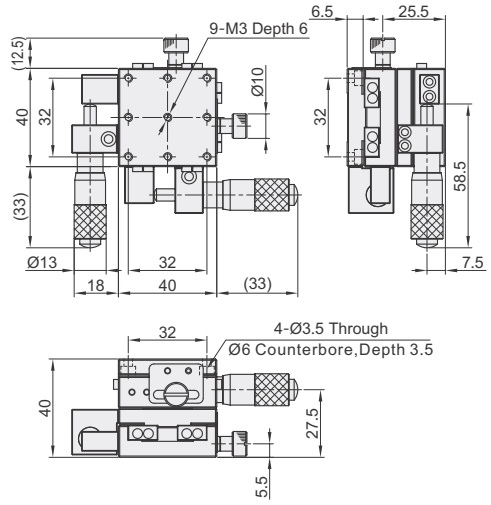

No.: 60

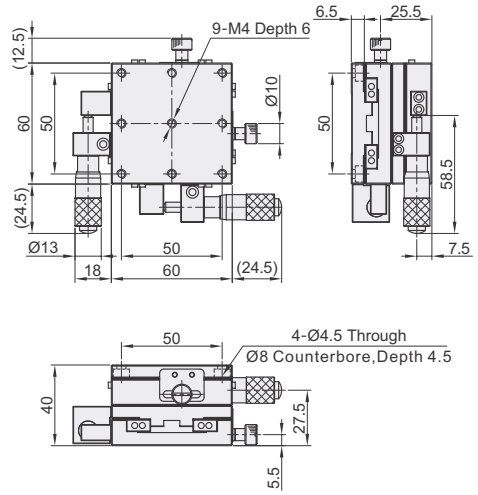

No.: 80

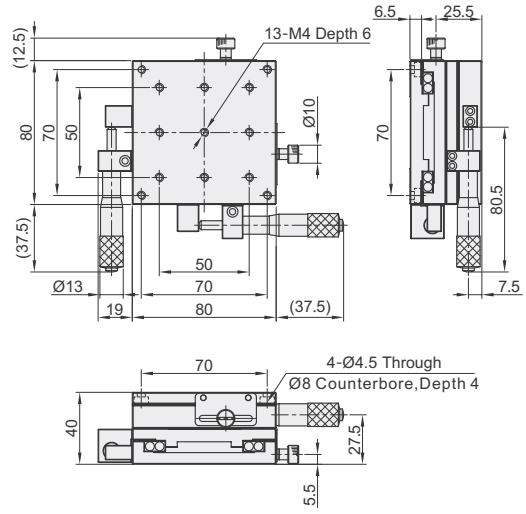

| Part Number | Stage Surface (mm) | Drive Position | Travel Distance (mm) | Minimum Graduation (µm) | Travel Accuracy (Parallelism) (µm) | Load Capacity (kgf) | Body Weight (kg) |
|-------------|--------------------|----------------|----------------------|-------------------------|------------------------------------|---------------------|------------------|
| Code | No. | | | | | | |
| E-EIC31 | 40 | Side | ±6.5 | 10 | 80 | 2 | 0.28 |
| | 60 | | | | | | |
| | 80 | | | | | | |



Code QR

Micrometer changed to left and right (reverse) position

Ordering Code QR

Spec.

Code QC

Micrometer changed to center position

Ordering Code QC



| Part Number | Stage Surface (mm) |
|-----------------|--------------------|
| Code No. | |
| E-EIC31 | 40 40×40 |
| | 60 60×60 |

E-EIC31—40

Optional Processing

| Part Number | Optional Processing |
|-----------------|---------------------|
| Code No. | Code |
| E-EIC31 | 40 QR |
| | 60 QC |

E-EIC31—40—QR

Economy Cross Roller Guide Stages

XY-Axis, Thin Micrometer Head



Self-made

| Code | Type | Drive Direction | Material | Surface Treatment |
|---------|-----------------|-----------------|----------------|-------------------|
| E-EIC36 | Micrometer Head | Thin | Aluminum Alloy | Black Anodize |

No.: 40

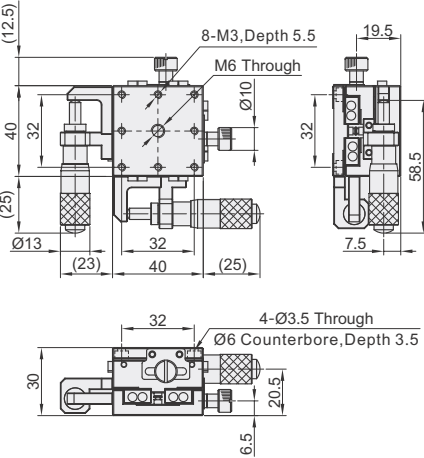

No.: 80

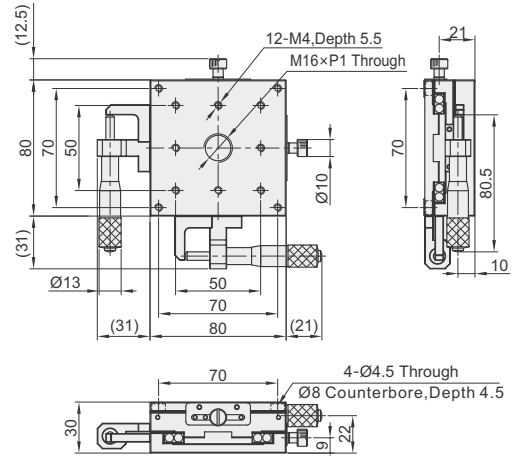

No.: 60

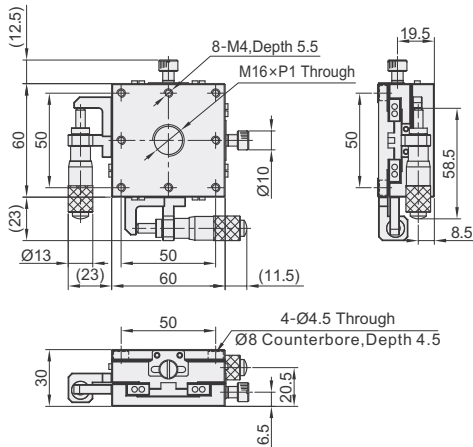

No.: 100

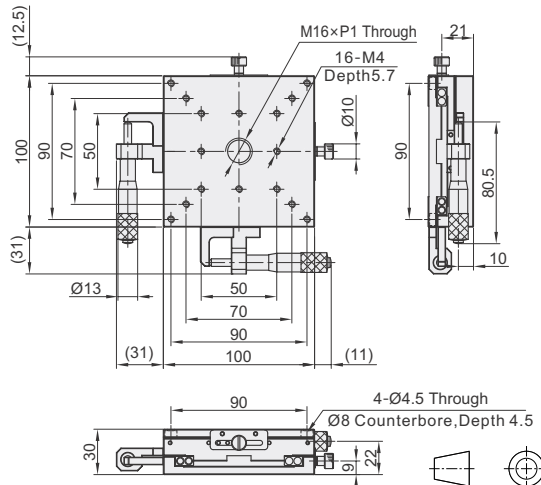

The first perspective

| Part Number | | Stage Surface (mm) | Drive Position | Travel Distance (mm) | Minimum Graduation (µm) | Travel Accuracy (Parallelism) (µm) | Load Capacity (kgf) | Body Weight (kg) |
|-------------|-----|--------------------|----------------|----------------------|-------------------------|------------------------------------|---------------------|------------------|
| Code | No. | | | | | | | |
| E-EIC36 | 40 | 40×40 | Side | ±6.5 | 10 | 60 | 2 | 0.3 |
| | 60 | 60×60 | | | | | | |
| | 80 | 80×80 | | | | | | |
| | 100 | 100×100 | | | | | | |



| Code | QR | QC |
|-------|---|---|
| Spec. | <p>Micrometer changed to left and right (reverse) position</p> <p>Ordering Code: QR</p> | <p>Micrometer changed to center position</p> <p>Ordering Code: QC</p> |



| Part Number Code | Stage Surface No. | Stage Surface (mm) |
|------------------|-------------------|--------------------|
| E-EIC36 | 40 | 40×40 |
| | 60 | 60×60 |

Optional Processing

| Part Number Code | No. | Optional Processing Code |
|------------------|-----|--------------------------|
| E-EIC36 | 40 | QR |
| | 60 | QC |

E-EIC36-40-QR

| Code | Type | Drive Direction | Material | Surface Treatment |
|---------|-----------------|-----------------|----------------|-------------------|
| E-EIC61 | Micrometer Head | Z-Axis | Aluminum Alloy | Black Anodize |



No.: 40

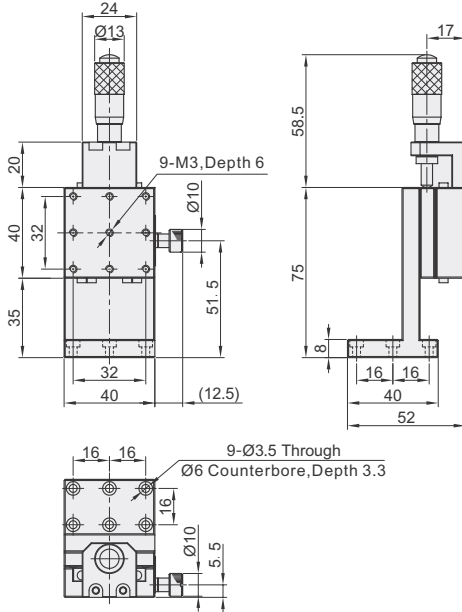

No.: 60

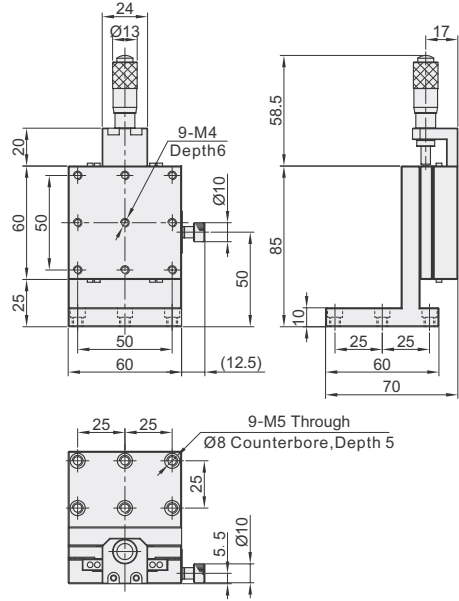

No.: 80

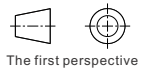
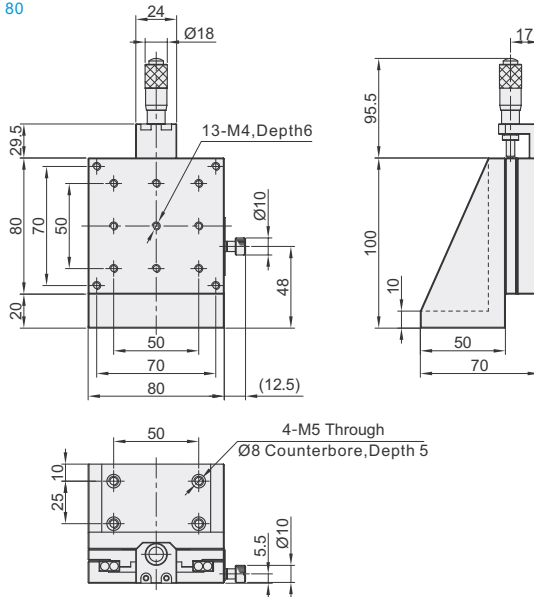

| Part Number | | Stage Surface (mm) | Drive Position | Travel Distance (mm) | Minimum Graduation (μm) | Load Capacity (kgf) | Body Weight (kg) |
|-------------|-----|--------------------|----------------|----------------------|-------------------------|---------------------|------------------|
| Code | No. | | | | | | |
| E-EIC61 | 40 | 40×40 | Center | ±6.5 | 10 | 1 | 0.14 |
| | 60 | 60×60 | | | | | |
| | 80 | 80×80 | | | | | |



| Part Number | Stage Surface |
|-------------|---------------|
| Code No. | (mm) |
| E-EIC61 40 | 40×40 |
| E-EIC61 60 | 60×60 |

Economy Cross Roller Guide Stages

Horizontal Z-Axis Micrometer Head

| Code | Type | Drive Direction | Material | Surface Treatment |
|---------|-----------------|-------------------|----------------|-------------------|
| E-EID01 | Micrometer Head | Horizontal Z-Axis | Aluminum Alloy | Black Anodize |

No.: 40

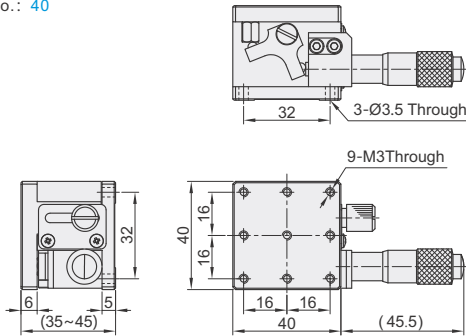

No.: 80

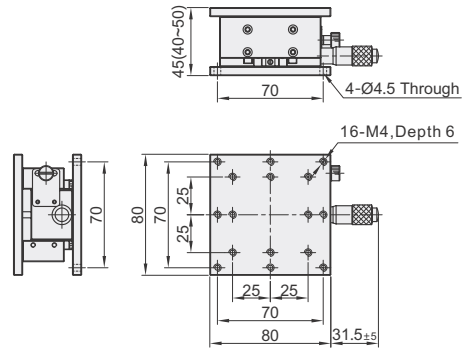

No.: 60

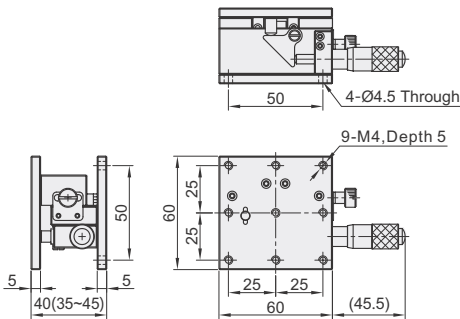

No.: 125

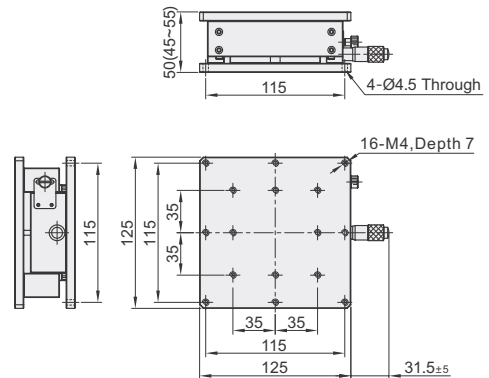

No.: 60L

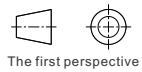
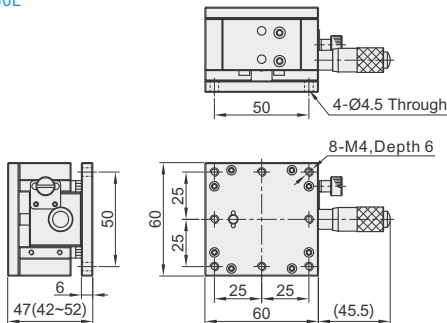

| Part Number | | Stage Surface (mm) | Travel Distance (mm) | Minimum Graduation (μm) | Parallelism (μm) | Load Capacity (kgf) | Body Weight (kg) |
|-------------|-----|--------------------|----------------------|-------------------------|------------------|---------------------|------------------|
| Code | No. | | | | | | |
| E-EID01 | 40 | 40×40 | | | | 2 | 0.17 |
| | 60 | 60×60 | | | 50 | 3 | 0.27 |
| | 60L | 60×60 | ±5 | 10 | | 6 | 0.39 |
| | 80 | 80×80 | | | | 9 | 1.2 |
| | 125 | 125×125 | | | 100 | 15 | 2 |



Please order as shown

| Part Number | Stage Surface (mm) |
|-------------|--------------------|
| Code No. 40 | 40×40 |
| Code No. 60 | 60×60 |

E-EID01 — 40

Economy Dovetail Slide Stages

X-Axis, Standard Rack & Pinion Feed



Self-made

| Code | Type | Drive Direction | Material | Surface Treatment |
|---------|--------------------|-----------------|----------------|-------------------|
| E-EIL01 | Rack & Pinion Feed | Standard | Aluminum Alloy | Black Anodize |

No.: 50

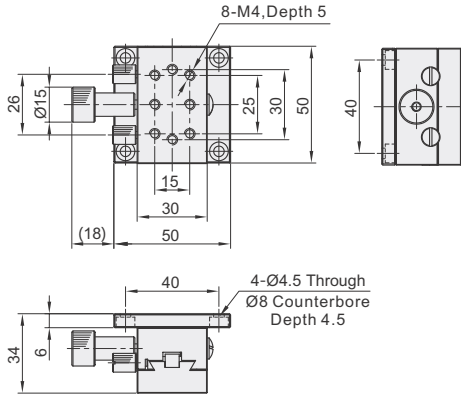

No.: 60

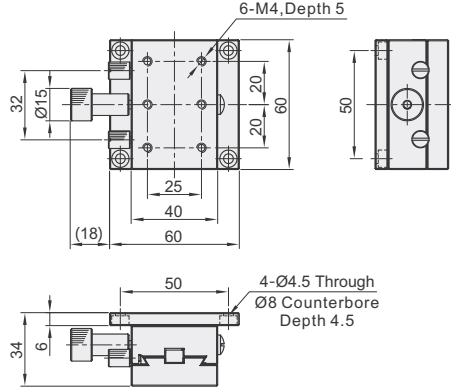

No.: 90

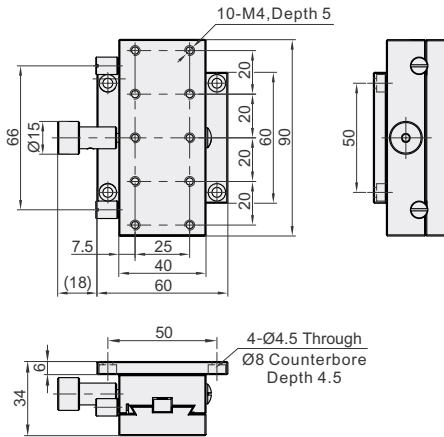

No.: 126

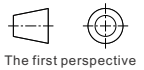
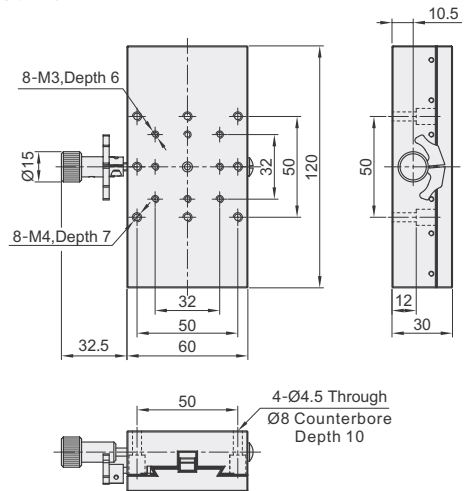

| Part Number | | Stage Surface (mm) | Drive Position | Travel Distance (mm) | Minimum Graduation (mm) | Parallelism (µm) | Load Capacity (kgf) | Body Weight (kg) |
|-------------|-----|--------------------|----------------|----------------------|-------------------------|------------------|---------------------|------------------|
| Code | No. | | | | | | | |
| E-EIL01 | 50 | 30×50 | Side | ±16 | 0.1 | 40 | 3 | 0.12 |
| | 60 | 40×60 | | ±21 | | | | |
| | 90 | 40×90 | | ±35 | | | | |
| | 126 | 60×120 | | ±50 | | | | |



| Part Number Code | Stage Surface (mm) No. |
|------------------|------------------------|
| E-EIL01 | 60 40×60 |
| E-EIL01 | 90 40×90 |

E-EIL01 — 60



Self-made

| Code | Type | Drive Direction | Material | Surface Treatment |
|---------|----------------------------|-----------------|----------------|-------------------|
| E-EIL06 | Rack & Pinion Feed Thin | X-Axis | Aluminum Alloy | Black Anodize |

No.: 50

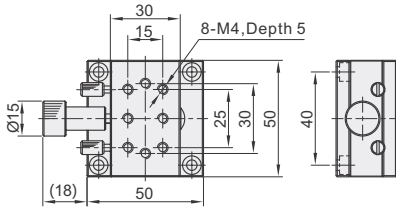

No.: 60

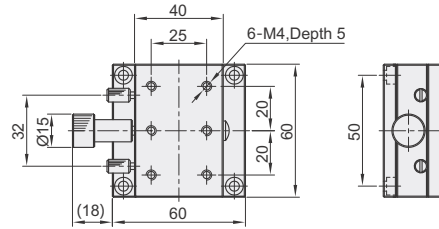

No.: 90

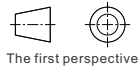
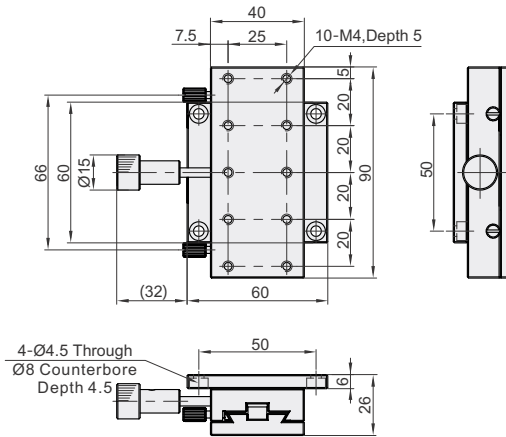

| Part Number | | Stage Surface (mm) | Travel Distance (mm) | Minimum Graduation (mm) | Parallelism (µm) | Load Capacity (kgf) | Body Weight (kg) |
|-------------|-----|--------------------|----------------------|-------------------------|------------------|---------------------|------------------|
| Code | No. | | | | | | |
| E-EIL06 | 50 | 30×50 | ±15 | | | 2 | 0.11 |
| | 60 | 40×60 | ±21 | 0.1 | 40 | 3 | 0.28 |
| | 90 | 40×90 | ±35 | | | | 0.4 |



Please order as shown

| Part Number | Stage Surface (mm) |
|-------------|--------------------|
| Code No. | 40×60 |
| E-EIL06 60 | 40×60 |
| E-EIL06 90 | 40×90 |

E-EIL06 — 60

Economy Dovetail Slide Stages

XY-Axis, Standard Rack & Pinion Feed

| Code | Type | Drive Direction | Material | Surface Treatment |
|---------|--------------------|-----------------|----------------|-------------------|
| E-EIL31 | Rack & Pinion Feed | Standard | Aluminum Alloy | Black Anodize |



Self-made

No.: 50

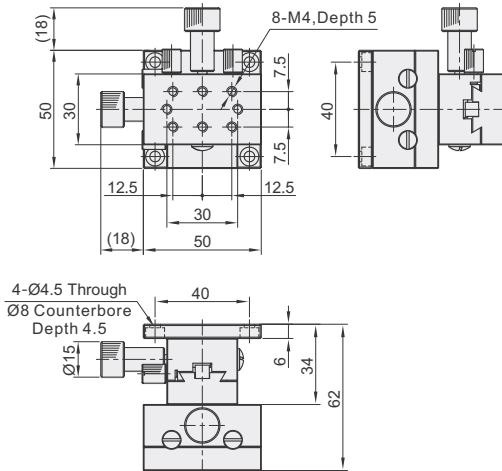

No.: 60

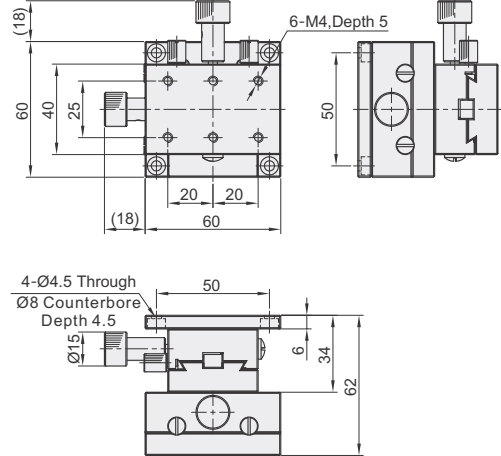

No.: 90

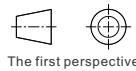
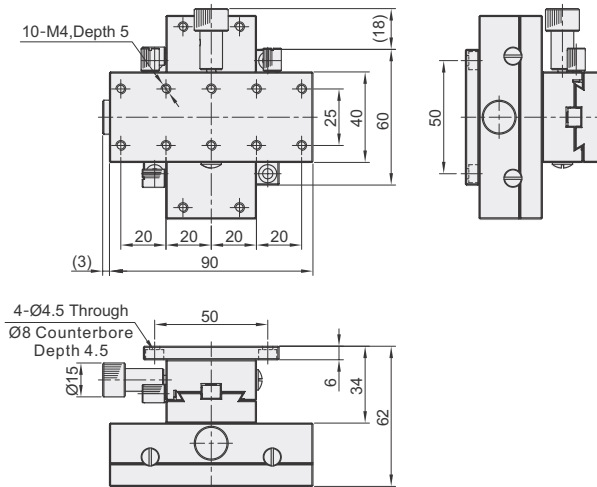

| Part Number | | Stage Surface (mm) | Travel Distance (mm) | Minimum Graduation (mm) | Parallelism (μm) | Load Capacity (kgf) | Body Weight (kg) |
|-------------|--------|--------------------|----------------------|-------------------------|------------------|---------------------|------------------|
| E-EIL31 | No. 50 | 30×50 | ±16 | 0.1 | 80 | 2.5 | 0.23 |
| | No. 60 | 40×60 | ±21 | | | | |
| | No. 90 | 40×90 | ±35 | | | | |



| Part Number | Stage Surface (mm) |
|-------------|--------------------|
| E-EIL31-60 | 40×60 |
| E-EIL31-90 | 40×90 |

| Code | Type | Drive Direction | Material | Surface Treatment |
|---------|----------------------------|-----------------|----------------|-------------------|
| E-EIL36 | Rack & Pinion Feed Thin | XY-Axis | Aluminum Alloy | Black Anodize |



Self-made

No.: 50

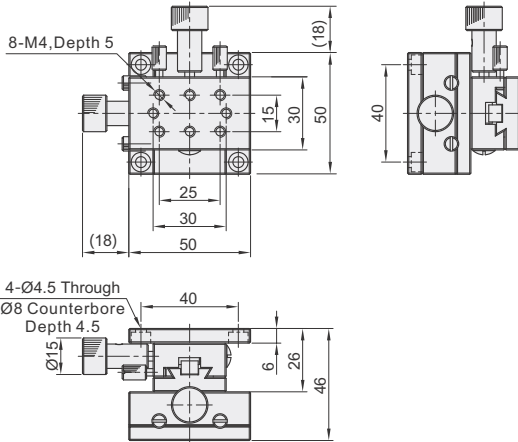

No.: 60

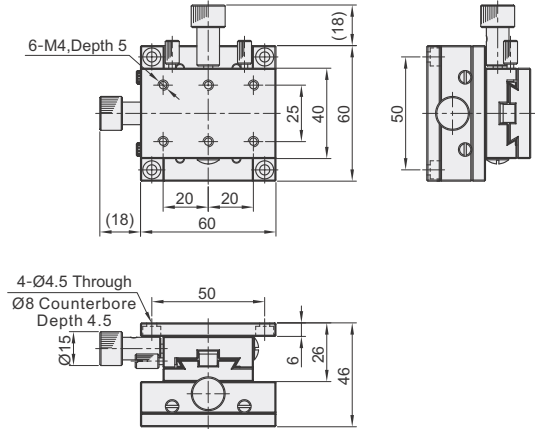

No.: 90

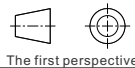
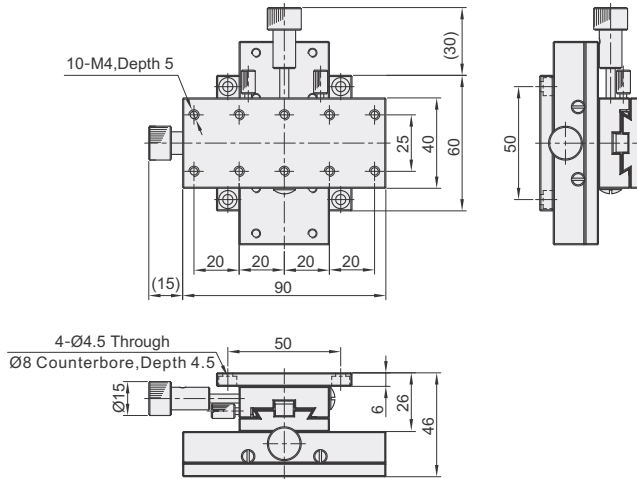

The first perspective

| Part Number | | Stage Surface (mm) | Travel Distance (mm) | Minimum Graduation (mm) | Parallelism (μm) | Load Capacity (kgf) | Body Weight (kg) |
|-------------|-----|--------------------|----------------------|-------------------------|------------------|---------------------|------------------|
| Code | No. | | | | | | |
| E-EIL36 | 50 | 30×50 | ±15 | 0.1 | 80 | 1.5 | 0.23 |
| | 60 | 40×60 | ±21 | | | | 0.56 |
| | 90 | 40×90 | ±35 | | | 2.5 | 0.81 |



| Part Number | Stage Surface (mm) |
|--------------|--------------------|
| Code No. | |
| 60 | 40×60 |
| 90 | 40×90 |
| E-EIL36 | |
| E-EIL36 — 60 | |

Economy Dovetail Slide Stages

Z-Axis, Standard Rack & Pinion Feed

Positioning Stages

| Code | Type | Drive Direction | Material | Surface Treatment |
|---------|--------------------|-----------------|----------------|-------------------|
| E-EIL61 | Rack & Pinion Feed | Standard | Aluminum Alloy | Black Anodize |



Self-made

No.: 50

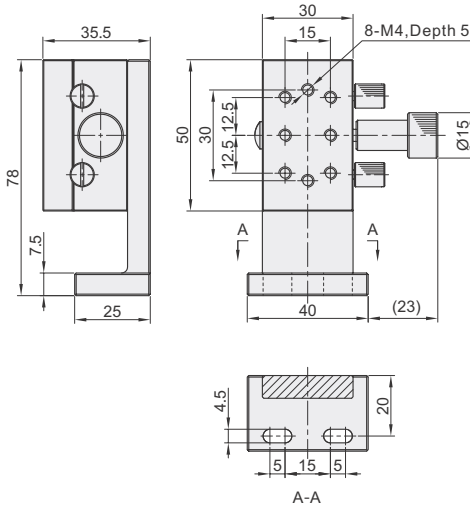

No.: 90

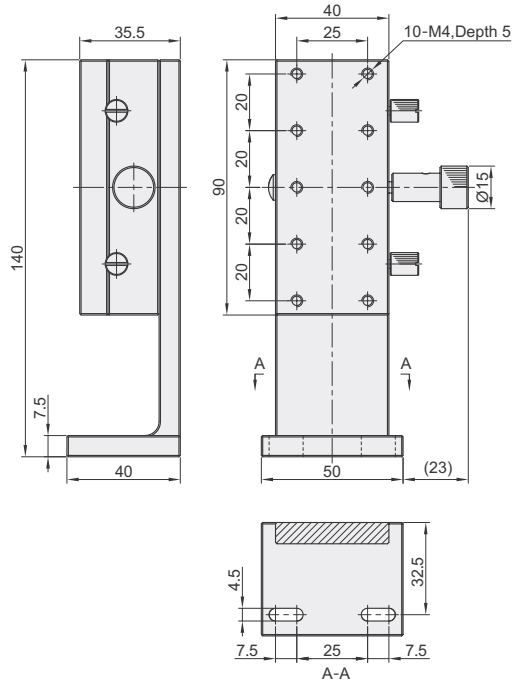

No.: 60

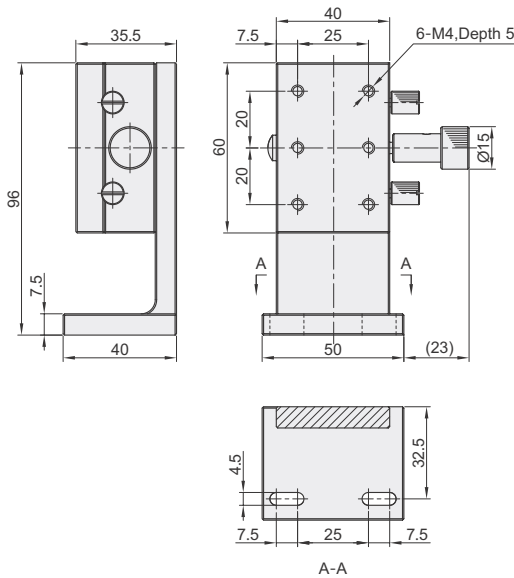

| Part Number | | Stage Surface (mm) | Travel Distance (mm) | Minimum Graduation (mm) | Load Capacity (kgf) | Body Weight (kg) |
|-------------|-----|--------------------|----------------------|-------------------------|---------------------|------------------|
| Code | No. | | | | | |
| E-EIL61 | 50 | 30×50 | ±16 | | 1 | 0.25 |
| | 60 | 40×60 | ±21 | 0.1 | 2 | 0.38 |
| | 90 | 40×90 | ±35 | | | 0.51 |



| Part Number | Stage Surface (mm) |
|-------------|--------------------|
| Code No. | (mm) |
| E-EIL61 | 40×60 |
| 90 | 40×90 |

E-EIL61 — 60

| Code | Type | Drive Direction | Material | Surface Treatment |
|---------|----------------------------|-----------------|----------------|-------------------|
| E-EIL66 | Rack & Pinion Feed Thin | Z-Axis | Aluminum Alloy | Black Anodize |

No.: 50

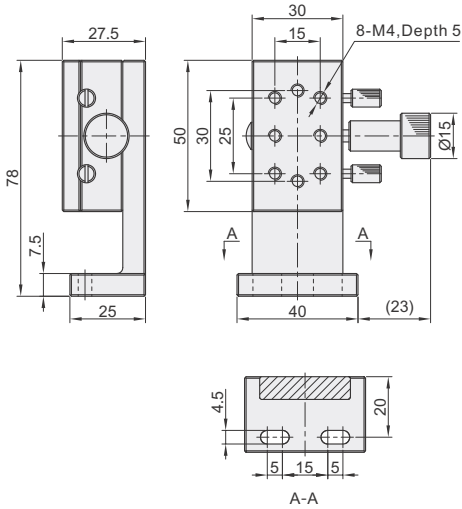

No.: 90

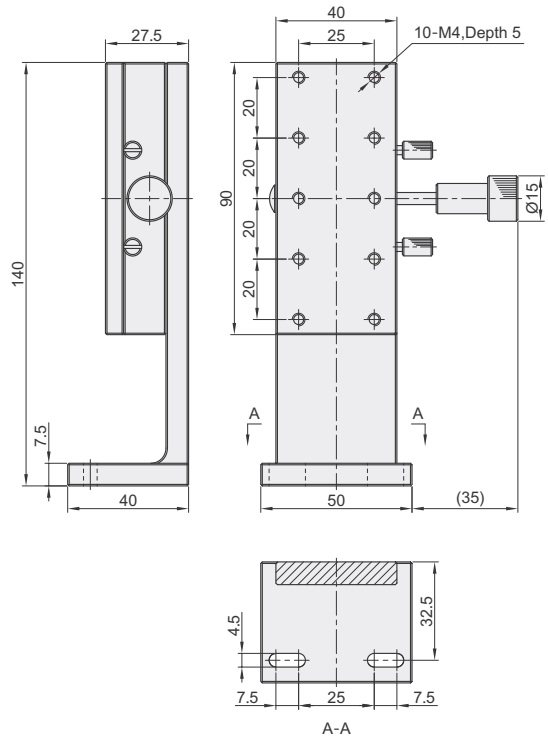

No.: 60

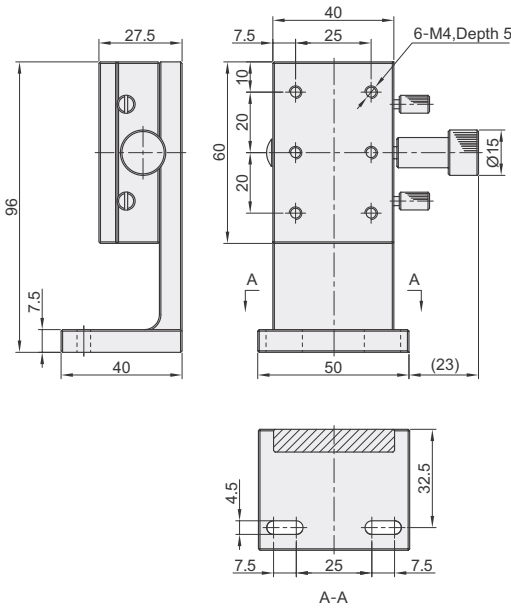

Positioning Stages
E 6

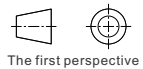

| Part Number | | Stage Surface (mm) | Travel Distance (mm) | Minimum Graduation (mm) | Load Capacity (kgf) | Body Weight (kg) |
|-------------|-----|--------------------|----------------------|-------------------------|---------------------|------------------|
| Code | No. | | | | | |
| E-EIL66 | 50 | 30×50 | ±15 | | 1 | 0.18 |
| | 60 | 40×60 | ±21 | 0.1 | | 0.35 |
| | 90 | 40×90 | ±35 | | 2 | 0.48 |



| Part Number Code | Stage Surface (mm) |
|------------------|--------------------|
| E-EIL66 50 | 30×50 |
| E-EIL66 60 | 40×60 |
| E-EIL66 90 | 40×90 |

E-EIL61 — 60

Economy Dovetail Slide Stages

X-Axis

Long Stroke, Rack & Pinion Feed

Positioning Stages
E8

| Code | Type | Drive Direction | Material | Surface Treatment |
|---------|--------------------|-----------------|----------------|-------------------|
| E-EIM01 | Rack & Pinion Feed | X-Axis | Aluminum Alloy | Black Anodize |



Self-made

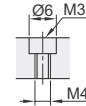
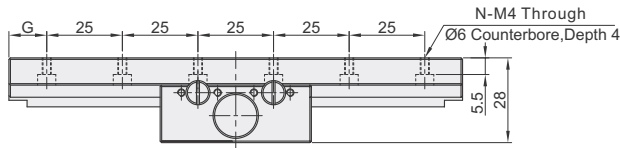
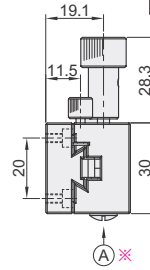
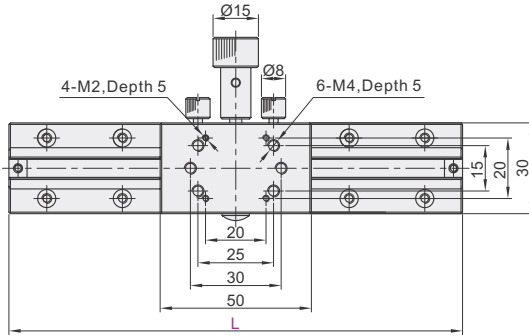

- M3 screws for mounting from top
- M4 screws for mounting from bottom

※ TightenⓄ (preloading adjusting screw) to the right with a slotted screwdriver, and the sliding resistance increases; loosen it to the left, and the sliding resistance decreases.

Ⓜ The product can choose two blocks, but the stroke should reduce the length of the corresponding blocks, and the total length of the slider cannot be greater than its own stroke.

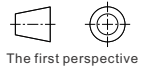

| Part Number | | G | N Number of Mounting Holes | Travel Distance (mm) | Travel per Rotation (mm) | Minimum Graduation (mm) | Parallelism (μm) | Load Capacity (kgf) | Body Weight (kg) |
|-------------|-----|------|----------------------------------|----------------------------|--------------------------------|-------------------------------|---------------------|---------------------------|---------------------|
| Code | L | | | | | | | | |
| E-EIM01 | 80 | 15 | 6 | ±30 | 18 | 0.1 | 40 | 3 | 0.15 |
| | 100 | | 8 | ±40 | | | | | 0.18 |
| | 150 | 12.5 | 12 | ±65 | | | 50 | | 0.23 |
| | 200 | | 16 | ±90 | | | | | 0.30 |



| Part Number | |
|-------------|-----|
| Code | L |
| E-EIM01 | 80 |
| E-EIM01 | 100 |

E-EIM01—L80